

**ESCO**  
SCIENTIFIC



# Airstream® G4

## Class II Type A2 Biological Safety Cabinets

*The Leading Energy-efficient, Quiet,  
and Ergonomic Biosafety Cabinet in the World*



# AIRSTREAM® G4 (AC2-NS G4) CLASS II TYPE A2 BIOSAFETY



## USB Port

- Export Data Logging
- Software Update
- Wired data transaction to BMS



## Zero Volt Relay Contact

- Free Relay Contact
- Exhaust Free Relay Contact

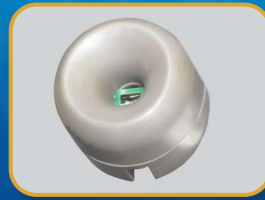

## Airflow Sensor

- Monitors real-time airflow for safety
- Alert the user if airflow is insufficient



## Centurion Touchscreen Controller

- 7" capacitive touchscreen, intuitive to use like smartphone
- Displays key safety information graphically on one screen
- Built-in guide to use the cabinet and respond to situations
- Centered and angled down for easy reach & viewing
- Datalogger to assist diagnostics and send info to BMS
- Optional: 21 CFR Part 11 Compliance



## One-Piece Interior Wall

- Double layer side walls with negative pressure
- Easy to reach service fixtures and outlets
- Large radius corner for easy cleaning

## Unique Side Walls

- Large corner radius for easy cleaning
- Glass hybrid wall is available (E-Series)
- Stainless steel side wall is available (S-Series)
- Hole-free side glass for increased safety



## Removable Paper Catch

- Easy-to-clean
- Optional pre-filter can be fitted



## Raised Ergonomic Arm Rest

- Helps prevent grille blocking
- Comfortable working posture



## Dished Work Tray

- Contains spillage
- Angled edge for easy cleaning
- V-shaped grille to prevent blocking
- Work tray holder for drain pan cleaning

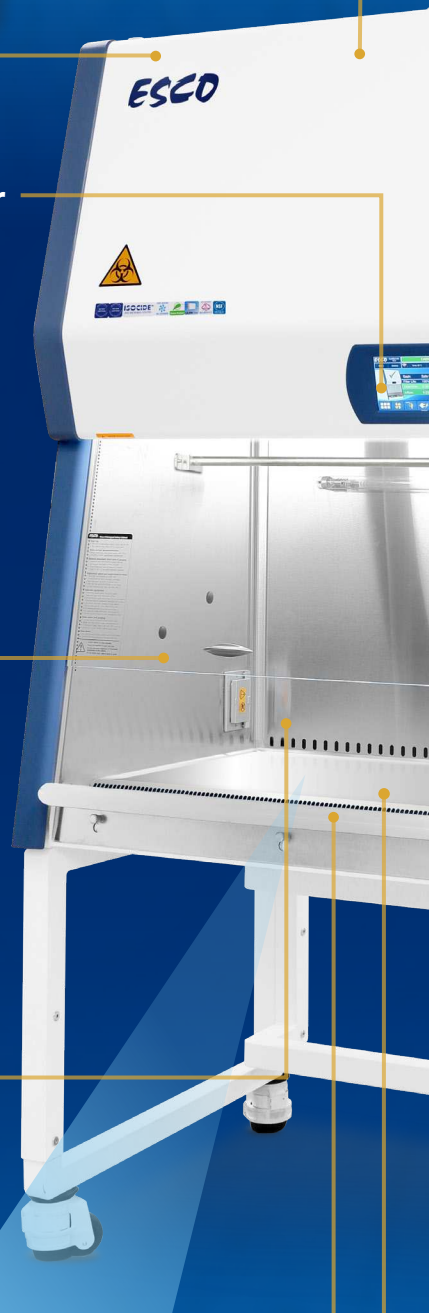



# CABINET, FEATURING ADVANCED TOUCHSCREEN CONTROLLER



**Airstream®**  
Class II Type A2 Biosafety Cabinet

Esco Airstream® NS G4 Class II Type A2 Biosafety Cabinet Available in 3 feet, 4 feet, 5 feet, and 6 feet models.

## Energy-efficient DC ECM Blower

- The leading energy efficient Class II Type A2 Biosafety Cabinet in the world with 70% energy savings compared to AC motor
- Stable airflow despite building voltage fluctuations and filter loading
- Standby mode to further reduce power consumption by 60%

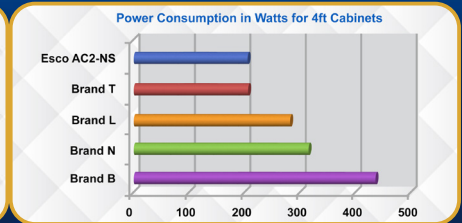
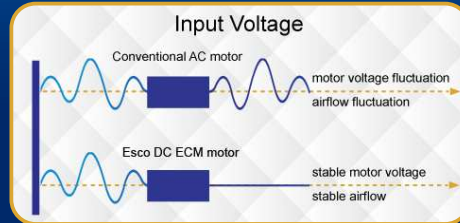

## ULPA Filter

- 10x Filtration efficiency of HEPA filter
- Creates ISO Class 3 work zone instead of industry-standard ISO Class 5
- Same 10 years filter life and replacement cost as HEPA filters

## Dynamic Chamber™

- Blower plenum and side walls are surrounded by negative pressure
- Prevents contaminants from escaping outside
- Steel plenum with Isocide™ coating, instead of flexible bag plenum, to prevent contamination leak

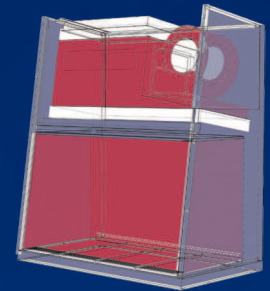

■ Positive pressure  
■ Negative pressure

## User Modified Pass-Through / Cable Port

- 3" Port with 1/4" hole on rubber membrane inside
- NSF-approved. Surrounded by negative pressure
- Allows cables and tubes to exit with fully closed sash



## Angled Sash

- 10° angled front to optimize user comfort, reduce glare and maximize reach into the work area

## ISOCIDE™ Powder Coat

- Silver-ion impregnated powder coat
- Inhibits microbial growth to improve safety
- Prevents the plenum from becoming biohazard landfill



## Standards Compliance and Certifications

Performance	Air Quality	Filtration	Electrical Safety	Electromagnetic Compatibility (EMC)
NSF / ANSI 49	ISO 14644.1, Class 3, Worldwide, US Fed Std 209E, Class 1 USA JIS B9920, Class 3, Japan	EN-1822 (H14), Europe IEST-RP-CC001, USA	UL 61010-1 3rd Ed, USA CSA22.2, No.1010-192, Canada IEC61010-1, Worldwide	EN IEC 61326-1 Group 1 / Class A

## Cabinet Filtration System

- Ambient air is pulled through front grille to create inflow, without going into the work surface. Inflow is joined by half of the downflow, to create front air curtain that is fine-tuned to create a large performance envelope. The combined air stream travels through the back air column towards the blower.
- Approximately 1/3 of the air in the common plenum is exhausted through the ULPA filter to the room. The remaining 2/3 of the air is passed through the downflow ULPA filter and into the work area as a vertical laminar flow air to create ISO Class 3 work surface and prevents cross contamination.
- Near the work surface, the downflow splits. About half goes to the front grille, and half goes to the rear grille. A small portion enters the side capture zones to prevent dead air corners (small blue arrows).
- The design was optimized to give large performance envelope, that provides operator and product protection at wide Inflow and Downflow variation from the Nominal point.

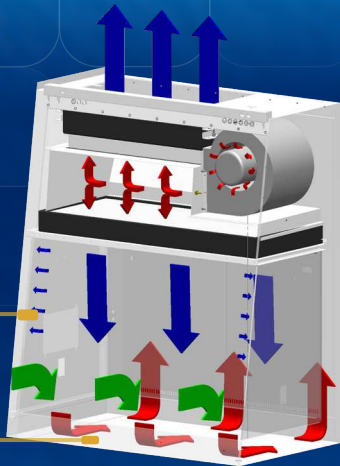

Dynamic air barrier, where inflow and downflow converge

Side capture zones

- ULPA-filtered air
- Unfiltered / potentially contaminated air
- Room air / Inflow air

## The Performance Envelope Concept

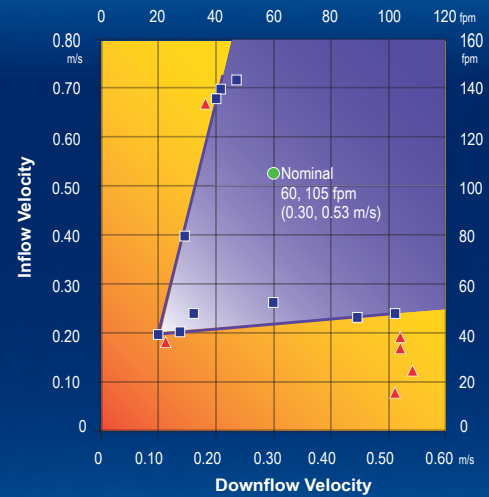

- Nominal Airflow
- Personnel / Product Protection
- Area of Personnel and Product Protection
- ▲ NO Personnel / Product Protection
- Area of NO Personnel and Product Protection

## Engineering Drawing

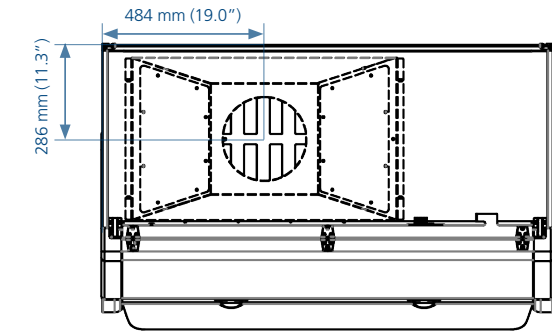

1. Esco 7" Touchscreen Control System
2. Tempered Glass - Sliding Sash Window
3. Stainless Steel Dished Work Tray
4. Electrical/Electronic Panel
5. Dimmable LED lamp
6. Provision for IV Bar (Optional)
7. Service Fixture Retrofit Kit Provision
8. Electrical Outlet (Max. 5 Amp Total)
9. Stainless Steel Side Wall
10. Stainless Steel Curved Armrest
11. Exhaust Collar (Optional)
12. Exhaust ULPA (H14) Filter
13. ECM Blower
14. Downflow ULPA (H14) Filter
15. UV Lamp
16. Cable Port (NSF Approved)
17. Caster wheel - Leveling Feet Combo

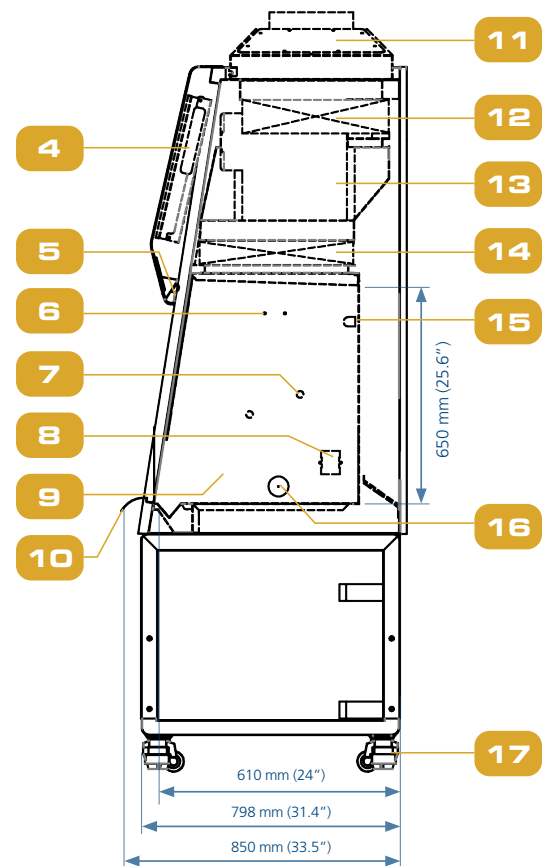
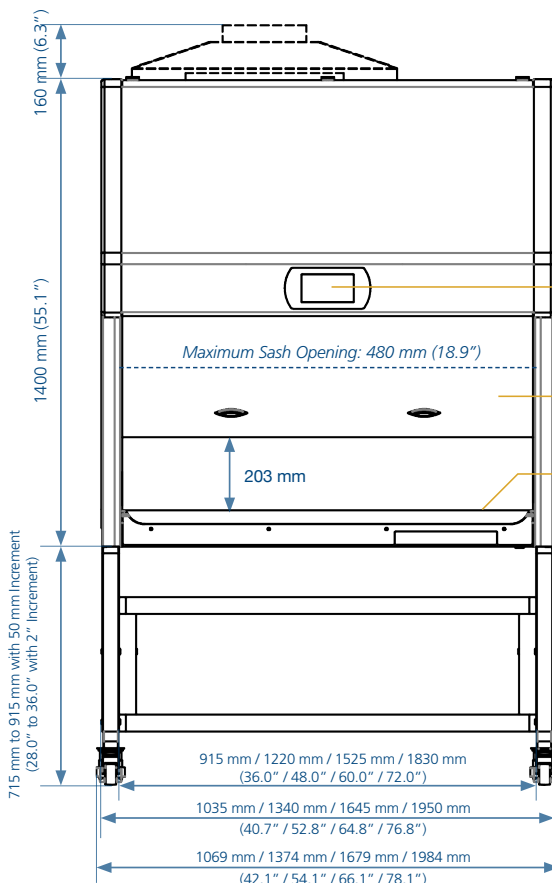

TECHNICAL SPECIFICATIONS

		AC2-259-NS G4 8" 2011757	AC2-359-NS G4 8" 2011429	AC2-459-NS G4 8" 2011403	AC2-559-NS G4 8" 2011431	AC2-659-NS G4 8" 2011433	
S-Series Stainless steel side walls	110-130 VAC, 50/60 Hz		AC2-359-NS G4 10" 2011926	AC2-459-NS G4 10" 2011927	AC2-559-NS G4 10" 2011928	AC2-659-NS G4 10" 2011929	
		220-240 VAC, 50/60 Hz	AC2-258-NS G4 8" 2011756	AC2-358-NS G4 8" 2011428	AC2-458-NS G4 8" 2011404	AC2-558-NS G4 8" 2011606	AC2-658-NS G4 8" 2011432
			AC2-358-NS G4 10" 2011604	AC2-458-NS G4 10" 2011605	AC2-558-NS G4 10" 2011606	AC2-658-NS G4 10" 2011607	
	E-Series Tempered glass side walls	110-130 VAC, 50/60 Hz		AC2-3E9-NS G4 10" 2011921	AC2-4E9-NS G4 10" 2011922	AC2-5E9-NS G4 10" 2011923	AC2-6E9-NS G4 10" 2011924
220-240 VAC, 50/60 Hz			AC2-2E8-NS G4 8" 2011754	AC2-3E8-NS G4 8" 2011420	AC2-4E8-NS G4 8" 2011422	AC2-5E8-NS G4 8" 2011424	AC2-6E8-NS G4 8" 2011426
			AC2-3E8-NS G4 10" 2011592	AC2-4E8-NS G4 10" 2011600	AC2-5E8-NS G4 10" 2011601	AC2-6E8-NS G4 10" 2011602	
Nominal Size		0.6 meter (2")	0.9 meter (3')	1.2 meter (4')	1.5 meter (5')	1.8 meter (6')	
External Dimensions with armrest (W x D x H)		730 x 850 x 1400 mm (28.7" x 33.5" x 55.1")	1035 x 850 x 1400 mm (40.7" x 33.5" x 55.1")	1340 x 850 x 1400 mm (52.8" x 33.5" x 55.1")	1645 x 850 x 1400 mm (64.8" x 33.5" x 55.1")	1950 x 850 x 1400 mm (76.8" x 33.5" x 55.1")	
Gross Internal Dimensions (W x D x H)		610 x 610 x 650 mm (24.0" x 24.0" x 25.6")	915 x 610 x 650 mm (36.0" x 24.0" x 25.6")	1220 x 610 x 650 mm (48.0" x 24.0" x 25.6")	1525 x 610 x 650 mm (60.0" x 24.0" x 25.6")	1830 x 610 x 650 mm (72.0" x 24.0" x 25.6")	
Usable Work Area		0.3 m <sup>2</sup> (3.2 ft <sup>2</sup> )	0.45 m <sup>2</sup> (4.9 ft <sup>2</sup> )	0.6 m <sup>2</sup> (6.5 ft <sup>2</sup> )	0.75 m <sup>2</sup> (8.2 ft <sup>2</sup> )	0.9 m <sup>2</sup> (9.8 ft <sup>2</sup> )	
Working Opening		203 mm (8") 254 mm (10")					
Maximum Opening		490 mm (19.3")					
Average Inflow Velocity		0.53 m/s (105 fpm)					
Average Downflow Velocity		0.30 m/s (60 fpm)					
Airflow Volume	Inflow / Exhaust Without Ducting	8"	232 cmh (140 cfm)	356 cmh (210 cfm)	473 cmh (280 cfm)	593 cmh (350 cfm)	709 cmh (417 cfm)
		10"		446 cmh (263 cfm)	594 cmh (350 cfm)	744 cmh (438 cfm)	891 cmh (525 cfm)
	Downflow	8"	369 cmh (224 cfm)	566 cmh (333 cfm)	751 cmh (442 cfm)	942 cmh (554 cfm)	1127 cmh (663 cfm)
		10"		566 cmh (333 cfm)	762 cmh (449 cfm)	953 cmh (561 cfm)	1143 cmh (673 cfm)
	Required Exhaust with Optional Thimble Exhaust Collar	8"	403 cmh (244 cfm)	600 cmh (353 cfm)	526 cmh (312 cfm)	627 cmh (370 cfm)	780 cmh (459 cfm)
		10"		614 cmh (362 cfm)	647 cmh (382 cfm)	786 cmh (463 cfm)	948 cmh (559 cfm)
	Static Pressure For Optional Thimble Exhaust Collar Measured 360mm (14 inches) from the top of exhaust collar	8"	15-25Pa	15-25Pa	25-35Pa	25-35Pa	45-55Pa
		10"		20-30Pa	30-40Pa	35-45Pa	50-60Pa
ULPA Filter Typical Efficiency		>99.999% at 0.1 to 0.3 micron, ULPA as per IEST-RP-CC001.3 USA >99.999% at MPPS, H14 as per EN 1822 EU					
Sound Emission per NSF / ANSI 49*	8"	60.0 dBA	55.8 dBA	59.5 dBA	59.8 dBA	62.8 dBA	
	10"		58.1 dBA	60.0 dBA	60.6 dBA	63.8 dBA	
ULPA Filter Typical Efficiency		>99.999% at 0.1 to 0.3 micron, ULPA as per IEST-RP-CC001.3 USA >99.999% at MPPS, H14 as per EN 1822 EU					
LED Lamp Light Intensity		108 ft candles (1162.5 lux)	117 ft candles (1260 lux)	122 ft candles (1313 lux)	113 ft candles (1216 lux)	114 ft candles (1227 lux)	
Cabinet Construction	Main Body	1.2 mm (0.05") / 18 gauge EG steel with Isocide™ oven-baked epoxy-polyester anti-microbial powder coating					
	Work Zone	1.5 mm (0.06") / 16 gauge, stainless steel 304, 4B finish					
	Side Walls	S-Series: 1.5 mm (0.06") / 16 gauge, stainless steel 304, 4B finish E-Series: UV-absorbing tempered glass, 6 mm (0.2"), colorless and transparent					
Electrical 110-130 VAC, 50/60 Hz**	Nominal Power Consumption (W)	8"	145	132	197	258	345
		10"		148	184	271	350
	Heat Load (BTU / Hr)	8"	495	450	672	880	1177
		10"		505	628	925	1194
	Cabinet Full Load Amps (FLA)	8"	15	15	15	15	15
		10"		15	15	15	15
	StandBy (Watt)	8"	0.25	34	33	40	49
		10"		31	25	36	34
StandBy (Ampere)	8"	25	0.54	0.50	0.57	0.75	
	10"		0.48	0.39	0.63	0.52	
Electrical 220-240 VAC, 50/60 Hz**	Nominal Power Consumption (W)	8"	140	162	192	274	378
		10"		154	197	290	380
	Heat Load (BTU / Hr)	8"	478	509	603	861	1187
		10"		484	619	911	1194
	Cabinet Full Load Amps (FLA)	8"	10	10	10	10	10
		10"		10	10	10	10
	StandBy (Watt)	8"	25	34	33	40	49
		10"		32	25	36	34
StandBy (Ampere)	8"	0.25	0.31	0.31	0.61	0.42	
	10"		0.30	0.26	0.59	0.32	
Net Weight		157 Kg (346 lbs)	203 Kg (448 lbs)	245 Kg (540 lbs)	303 Kg (668 lbs)	361 Kg (796 lbs)	
Shipping Weight		210 Kg (463 lbs)	231 Kg (509 lbs)	300 Kg (661 lbs)	369 Kg (814 lbs)	443 Kg (977 lbs)	
Shipping Dimensions, Maximum (W x D x H)		850 x 850 x 1950 mm (33.5" x 33.5" x 76.8")	1200 x 850 x 1950 mm (47.2" x 33.5" x 76.8")	1450 x 850 x 1950 mm (57.1" x 33.5" x 76.8")	1720 x 850 x 1950 mm (67.7" x 33.5" x 76.8")	2050 x 850 x 1950 mm (80.7" x 33.5" x 76.8")	
Shipping Volume		1.4 m <sup>3</sup> (49.4 f <sup>3</sup> )	2.0 m <sup>3</sup> (70.64 f <sup>3</sup> )	2.5 m <sup>3</sup> (88.2 f <sup>3</sup> )	3.0 m <sup>3</sup> (105.9 f <sup>3</sup> )	3.6 m <sup>3</sup> (127.1 f <sup>3</sup> )	

Disclaimer: Technical Specifications may be subjected to further changes without prior notice.

\*Noise reading in open field condition / anechoic chamber. Noise reading in normal room varies by room size, layout, and background noise, but may reach roughly 3-4 dBA above these values.

\*\* Electrical power consumption is a measurement of new unit within nominal set point. Result may vary due to several independent variables.

## Options and Accessories

Model	AC2-2S8-NS G4 8"	AC2-3S8-NS G4 8"	AC2-4S8-NS G4 8"	AC2-5S8-NS G4 8"	AC2-6S8-NS G4 8"
	AC2-2S8-NS G4 10"	AC2-3S8-NS G4 10"	AC2-4S8-NS G4 10"	AC2-5S8-NS G4 10"	AC2-6S8-NS G4 10"
UV Lamp	UV-15A-L 5170251		UV-30A-L 5170255		
Electrical Outlet (Direct mounted) max 2	EO-H_				
	EO-GFCI 5170251				
IV Bar	IV-605 5170498	IV-910 5170499	IV-1215 5170231	IV-1520 5170500	IV-1825 5170501
Support Stand w/ Castors wheel and levelling feet (28" and 36")	STA-2A0 5131339	STA-3A0 5131340	STA-4A0 5131341	STA-5A0 5131427	STA-6A0 5131389
EU SF – Gas – 20mm	SF-1G20 5170410				
EU SF – Vacuum – 20mm	SF-1V20 5170457				
EU SF – Air – 20mm	SF-1A20 5170502				
EU SF – Nitrogen – 20mm	SF-1N20 5170503				
EU SF – Water – 20mm	SF-1W20 5170458				
EU SF – Universal – 22mm	SF-2U22 5170504				
Copper Piping	COPPER PIPING 5170026				
Thimble Exhaust Collar	ECO-F1-AC2-2FT G4 5171229	ECO-F1-AC2-3FT G4 5171097	ECO-F1-AC2-4FT G4 5171098	ECO-F1-AC2-5FT G4 5171099	ECO-F1-AC2-6FT G4 5171100
Anti-blowback Valve 10inch	ABBV-10S 5170354				
Exhaust Damper (B2-Damper)	B2-DAMPER 5170104				
Front Decon cover with VHP IN PORT	FRONT DECON COVER W/ VHP IN PORT AC2-2-G4 5171319	FRONT DECON COVER W/ VHP IN PORT AC2-3-G4 5171321	FRONT DECON COVER W/ VHP IN PORT AC2-4-G4 5171323	FRONT DECON COVER W/ VHP IN PORT AC2-5-G4 5171325	FRONT DECON COVER W/ VHP IN PORT AC2-6-G4 5171327
Top Decon cover with VHP OUT PORT	TOP DECON COVER W/ VHP OUT AC2-2-G4 5171320	TOP DECON COVER W/ VHP OUT AC2-3-G4 5171322	TOP DECON COVER W/ VHP OUT AC2-4-G4 5171324	TOP DECON COVER W/ VHP OUT AC2-5-G4 5171326	TOP DECON COVER W/ VHP OUT AC2-6-G4 5171328
TOP BOX With VHP OUT (1 inch diameter)	TOP BOX W/ VHP-OUT AC2-2-NS G4 5171350	TOP BOX W/ VHP-OUT AC2-3-NS G4 5171298	TOP BOX W/ VHP-OUT AC2-4-NS G4 5171299	TOP BOX W/ VHP-OUT AC2-5-NS G4 5171300	TOP BOX W/ VHP-OUT AC2-6-NS G4 5171301
Thimble Exhaust Collar with alarm and VHP-OUT-PORT	ECO-F1-W/ VHP OUT AC2-2FT G4 5171351	ECO-F1-W/ VHP OUT AC2-3FT G4 5171352	ECO-F1-W/ VHP OUT AC2-4FT G4 5171353	ECO-F1-W/ VHP OUT AC2-5FT G4 5171354	ECO-F1-W/ VHP OUT AC2-6FT G4 5171355
Pre-Filter, Paper catch (Black Foam only)	PF-40 5090060	PF-41 5090061	PF-42 5090062	PF-43 5090063	PF-41 X 2 5090061
Arm Rest Padding	MEWREST 5170127				
Foot Rest	FT-REST 5170073				
IQOQ Protocol	Hardcopy 9010179 Softcopy 9010179-A				
FAT	RSR-020				



# ESCO

LIFESCIENCES GROUP

*Improving Lives through Science*

## ESCO SCIENTIFIC



- Animal Research Workstation
- Biological Safety Cabinet
- CO<sub>2</sub> Incubator
- Ducted Fume Hood
- Ductless Fume Hood
- Filtered Storage Cabinet
- Laboratory Centrifuge
- Laboratory Oven and Incubator
- Laboratory Refrigerator and Freezer
- Laboratory Shaker
- Laminar Flow Cabinet
- PCR Cabinet
- Powder Weighing Balance Enclosure
- Thermal Cycler
- Ultra-low Temperature Freezer

## ESCO MEDICAL



- Time-Lapse Incubator
- Benchtop Incubator
- ART Workstation
- CO<sub>2</sub> Incubator
- Anti-Vibration Table
- Gas Analyser

## ESCO Healthcare

"Discovery to Delivery"



ESCO  
PHARMA

ESCO  
TaPestle

ESCO  
FACILITY CELL

Pharmaceutical Manufacturing, Pharmacy Compounding, and Bioprocessing Tools

## ESCO ASTER



CRDMO Services

**ESCO LIFESCIENCES GROUP**  
42 LOCATIONS IN 21 COUNTRIES ALL OVER THE WORLD

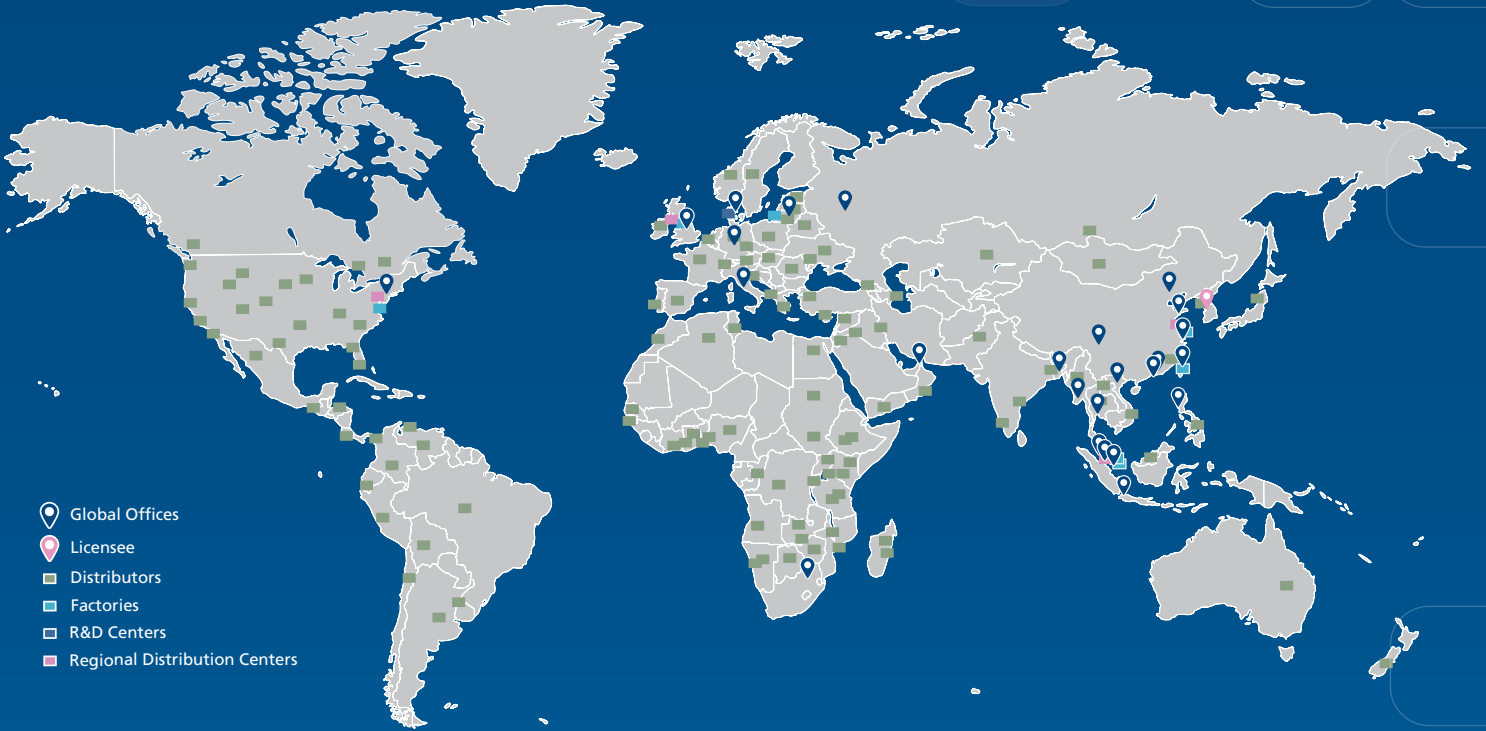

- 📍 Global Offices
- 📍 Licensee
- 🟩 Distributors
- 🟩 Factories
- 🟩 R&D Centers
- 🟩 Regional Distribution Centers

*Follow us on social media, download our apps,  
and scan the QR code for more info.*



@EscoLifesciences



@EscoLifesciences



@EscoLifesci



@Esco



@EscoLifesciences



@EscoLifesciences



Esco Lifesciences



Esco Lifesciences

**ESCO**<sup>®</sup>  
LIFESCIENCES GROUP

Esco Micro Pte. Ltd. • 19 Changi South Street 1 • Singapore 486779  
Tel +65 6542 0833 • mail@escolifesciences.com  
www.escolifesciences.com

Esco Technologies, Inc. • 903 Sheehy Drive, Suite F, Horsham, PA 19044, USA  
Tel: +1 215-441-9661 • Fax 484-698-7757  
eti.admin@escolifesciences.com

Esco Lifesciences Group Offices: Bangladesh | China | Denmark | Germany | Hong Kong | India | Indonesia | Italy | Japan | Lithuania  
| Malaysia | Myanmar | Philippines | Russia | Singapore | South Africa | South Korea | Taiwan | Thailand | UAE | UK | USA | Vietnam