



Containment Barrier Isolator (CBI)

Your Practical Solution to cGMP Compliance

Product Brochure (English)

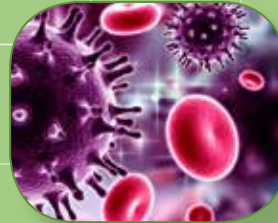

Table of Contents

Isolation Technology	3
Containment Barrier Isolator	
• Introduction to CBI	4
• Key Features	6
• Quick Guide to CBI Models	8
Containment Barrier Isolator (CBI) Models	
• Containment Barrier Isolator – Unidirectional (CBI-U)	10
• Containment Barrier Isolator – Turbulent (CBI-T)	14
• Containment Barrier Isolator – Class III (CBI-III)	18
• Containment Barrier Isolator – Hybrid (CBI-H) (Convertible Class III/I BSC)	22
• List of Options for CBI Models	25
• Equipment Integration	27
BioVap™	28
Pressure Test	29
Safe Glove Change Procedure Replacing Disposable Gloves	30
Replacing the Sleeves	31

Welcome to Esco!



PT Esco Bintan Indonesia
Cert. No: 651333/E



Esco Micro Pte Ltd
Cert. No: 651076



PT Esco Bintan Indonesia
Cert. No: Q2N130383797001

Esco's Vision is to provide enabling technologies for scientific discoveries to make human lives healthier and safer.

Since Esco was founded in 1978, our company has earned a reputation for innovations in laboratory equipment and in the pharmaceutical industry worldwide. Today, Esco has emerged as a market leader in containment, clean air, pharmaceutical, and laboratory equipment technologies with active sales in more than 100 countries and has direct company offices in the top ten geospecific markets.

From our headquarters in Singapore, Esco directs a highly efficient research, product development, manufacturing, and customer service program. We are the only company in the market that has completely configured to export most of what we manufacture. Our many languages and cultures, customs and traditions, and modern business management techniques blend into a single effort focusing on customer service, one customer at a time. As you learn more about Esco, you will understand why *World Class. Worldwide.* is more than just a phrase. It's part of who we are, where we are from, and where we are going.

Watch Esco's Corporate Video!



Research and Development



Esco engineers are located in different technology centers in Singapore, China, Europe, and the USA, managing extensive research and development programs. As we expand globally, so does our growing patent portfolio as Esco products reflect the best contemporary designs in our core competencies:

- Embedded system, sensor and software development and integration
- Containment engineering for biohazards, chemical vapors and hazardous powders
- Decontamination cycle development
- Computational fluid dynamics
- Temperature, humidity, gas and environmental control
- Imaging systems
- Wireless and remote monitoring
- cGMP laboratory design

Containment Barrier Isolator (CBI)

Most Diverse Isolator Range



ISOLATION TECHNOLOGY

Isolation containment systems provide inherently superior environment compared to open front clean air devices such as laminar flow clean benches and biological safety cabinets. Isolators can provide specialized environment needed by certain processes or products, such as those that require light protection and inert environment. USP and PIC/S guidelines specify that isolators may be situated in an area subject to less severe environmental controls compared with open front clean air devices.

When used as part of a system that includes operator aseptic technique training, process validation, expiration setting, and product quality maintenance, isolators are an effective solution in providing protection for the product/process, operator, and the environment. Isolators reduce operating and renovation costs, take up less space, and are easier to maintain.

Isolation Technology can be utilized in the following applications:

- Sterility Testing
- Aseptic Processing
- Cell Processing
- Potent Powder Handling
- Toxic Containment
- Hospital Pharmacy Compounding (Chemotherapy/TPN)
- Radiopharmaceutical Dispensing
- Biomedical Isolation
- Biosafety Levels (BSL) 3 and 4
- Research and Development
- Surgical and other Miscellaneous Uses

CONTAINMENT BARRIER ISOLATOR (CBI)

Your Practical Solution to GMP Compliance

Containment Barrier Isolator (CBI) facilitates the isolation of a product or process while providing the required conditions for a sterile/ aseptic and hazardous environment. This equipment provides a comprehensive range of personnel and product protection in addition to protection for the surrounding work areas and the environment.

CBI is available in 4 models to provide the needs of different applications and industries.

- Containment Barrier Isolator - Unidirectional
- Containment Barrier Isolator - Turbulent
- Containment Barrier Isolator – III (Class III Biosafety Cabinet)
- Containment Barrier Isolator – Hybrid (Class III/Class I Convertible Biosafety Cabinet)



CBI-U



CBI-III



CBI-T



CBI-H

Standard Features of CBI

- Full stainless-steel isolator with SS 304 exterior and fully-welded SS 316L internal chambers with rounded covered corners
- Self-contained design of control systems and electrics allowing simple plug-in installation
- Safe change glove system allows the changing of gloves while maintaining aseptic conditions inside the chambers
- HEPA (H14) filters with a typical efficiency of > 99.999% at 0.3 microns provide superior ISO Class 5 air cleanliness
- Pressure-tested Class 2 as per ISO 10648-2 standards
- Esco HMI controller supervises all functions and monitors airflow and pressures in real-time
- Ergonomically angled front and circular glove ports (minimal crevices, no exposed bolts and nuts) improve reach and comfort
- The airlock pass-thru ensures work zone remains sterile during insertion and removal of items
- The electromagnetic interlocking door mechanism with time-delayed ingress/egress control allows sufficient time to minimize transfer of contamination
- FDA-approved static seals
- Foot switch provides hands-free access to opening of the magnetic interlock minimizing operator fatigue during transfer procedures
- Sliding tray facilitates material transfer without the operator having to reach into the pass chamber interchange area
- Can be integrated with multiple equipment to ensure ease of workflow

Containment Barrier Isolator (CBI)

CONTROL SYSTEM

The Esco HMI control system supervises operation of all cabinet functions. Controls are configurable to meet user requirements.

Features of the main control panel include:

- Work zone and pass through pressures are monitored and displayed on the LCD screen.
- Continuous monitoring and display of cabinet status on large, easy-to-read LCD display.
- Alarm package is available for users with more sophisticated requirements.



FAN EFFICIENCY

The CBI fan system is designed for maximum energy efficiency and minimal maintenance.

- Centrifugal, direct-drive, external rotor motors reduce operating costs.
- Esco motor/fan orientations minimize noise and vibration.
- Built-in solid-state variable speed controllers are infinitely adjustable from Off to Maximum

WARRANTY

One year warranty (excluding consumables).

Consumables are gloves, ballast, fluorescent, and filters. The warranty will cover all other parts including the blower, fan switch, and electrical main board. During the period of warranty, any repair, modification, testing and commissioning performed by any unauthorized party other than Esco Service Team will void the warranty of the unit.

SAFETY AND CERTIFICATION

All components used in Esco products meet or exceed all applicable safety requirements.

- Each cabinet is individually factory-tested for compliance to safety standards.
- Documentation specific to the cabinet serial number is maintained on file.

	Design	Cabinet Performance	Air Cleanliness	Electrical Safety
Standard Compliance	USP <797> and <800>, USA NIOSH, OSHA, Designed in compliance to international GMP standards	Class 2 Leak Tight Containment as per ISO 10648-2, CETA CAG-002-2006	ISO 14644-1 Class 3 (at rest), Class 5 (in operation), EU GMP Grade A, Worldwide JIS B9920, Class 3, Japan BS 5295, Class 1, UK	IEC 61010-1, Worldwide EN 61010-1, Europe UL 61010-1, USA CAN/CSA-22.2, No. 61010-1



Damper

- Inbuilt dampers to allow pressure testing without having to use cover plates, tape & silicone
- Close or open the isolator chambers from the external room environment

Escob HMI

- Supervises all functions and monitors cabinet performance in real time
- Large graphical LCD to illustrate isolator operating parameters



Relative Humidity and Temperature Sensor

- Monitors relative humidity and temperature of the chambers
- Formed in a single unit with only one measuring probe installed at the chamber work area



Magnetic InterLock

- Ensures safety and containment between the Pass Chamber and the Process Chamber
- Time delay effect from closing one door before opening the opposite door



Process Chamber

- Perform work operation. Environmental conditions are being monitored, regulated and maintained.
- Chamber supply and Return HEPA filters complying with EN1822 having an MPPS efficiency of 99.9995%
- ISO 5 environment facilitating aseptic processing in an EU GMP grade A condition

EC Centrifugal Fan

- Minimized noise and vibration, energy efficient, compact design, minimal maintenance
- Controlled in a closed loop to ensure correct airflow and correct internal pressure



Emergency Stop Button (E-Stop)

- Easy access for manual electrical power turn off and equipment shutdown during emergencies

Tempered Glass

- Toughened safety glass for increased protection
- Frameless with highly polished rounded edges to increase cleanliness and maximize door vision panel for ergonomic comfort



Sliding Tray

- Prevents operator fatigue during transfer procedures
- Removable, for easy cleaning



Pass Chamber

- Gateway for materials entering and exiting the Process chamber
- Furnished with electromagnetic interlocked doors

Clean Design Work Area

- Coved corner for easy cleaning
- Constructed with non-corrosive 316L stainless steel



Foot Switch

- Provides hands-free access to opening of the magnetic interlock minimizing operator fatigue during transfer procedures

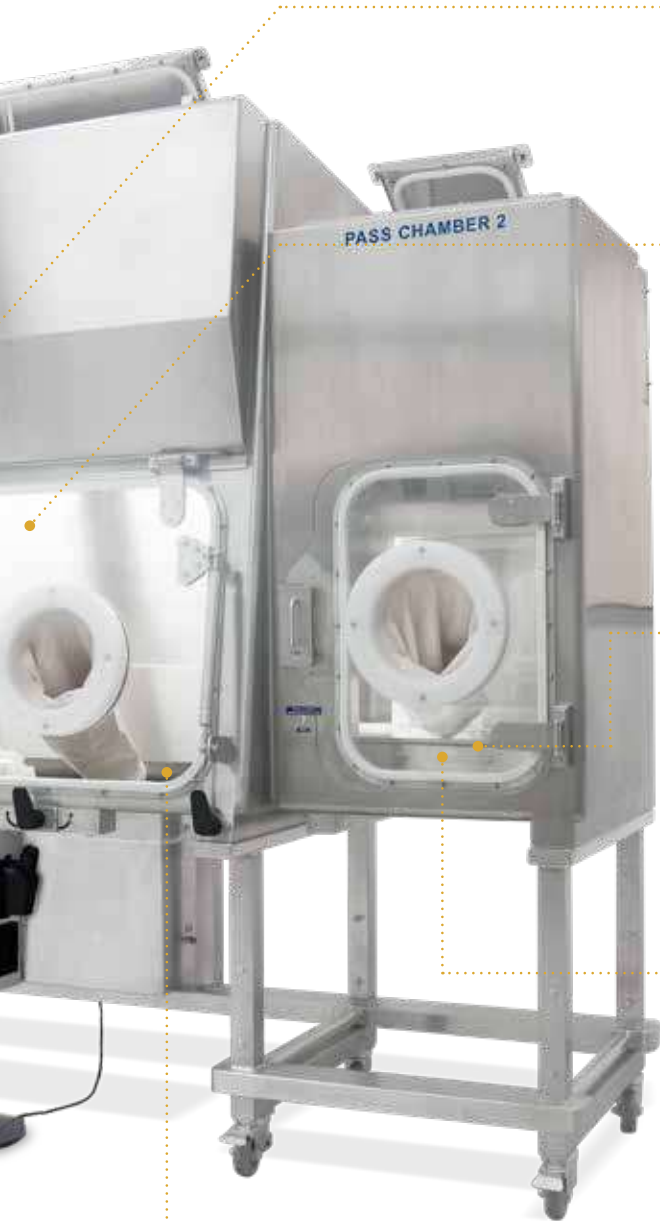

QUICK GUIDE TO CONTAINMENT BARRIER ISOLATOR (CBI) MODELS



Containment Barrier Isolator – Unidirectional (CBI-U)

Models Available:

- Positive Pressure or Negative Pressure
- Recirculating or Total Exhaust/Single-Pass
- 2,3, or 4 gloves

Common Applications: PPharmacy compounding (Chemo-therapy/TPN), cell processing, aseptic processing, sterility testing, medical device manufacturing, radiopharmacy, cosmeceutical, nutraceutical, food and beverage application, research and development.

Standard Compliance: ISO 10648-2:1994, EN ISO 14644-1:2015, USP <797>/<800>, GMP, PIC/S, CETA CAG-001-2005, CETA CAG-002-2006

8



Containment Barrier Isolator – Turbulent (CBI-T)

Models Available:

- Negative Pressure only
- Total Exhaust/Single-Pass
- 2,3, or 4 gloves

* Models with static seal (CBI-T-SS) or inflatable seal (CBI-T-IS)

Common Applications: Potent powder handling, HPAPI QC Testing, and research and development

Standard Compliance: ISO 10648-2, GMP, PIC/S

Isolator Unit	Model		No. of Gloves - Internal Width (mm)	
CBI	U	Unidirectional	2G	2 Gloves - 1200mm
	T-SS	Turbulent Static Seal	3G	3 Gloves - 1600 mm
	T-IS	Turbulent Inflatable Seal	4G	4 Gloves - 2000 mm
	3	Class III BSC		
	H	Hybrid (Convertible Class III to Class I)		



Containment Barrier Isolator – Class III (CBI-III)

Models Available:

- Negative Pressure only
- Total Exhaust/Single-Pass
- 2,3, or 4 gloves

Common Applications: Biosafety Levels 1 to 4 handling, virus production, vaccine production

Standard Compliance: EN 12469:2000, NSF/ANSI 49-2016, ISO 14644-1:2015, USP <797>/<800>, GMP, PIC/S.



Containment Barrier Isolator – Hybrid (Convertible Class III/ Class I Biosafety Cabinet)

Models Available:

- Convertible Class III to Class I BSC
- 2,3, or 4 gloves

Common Applications: Biosafety Levels 1 to 4 handling, virus production, vaccine production

Standard Compliance: EN 12469:2000, ISO 14644-1:2015, USP <797>/<800>, GMP, PIC/S

	Voltage Code	Pressure	Airflow	Number of PTC	Type of PTC
8	220-240 VAC, 50/60 Hz	N Negative	R Recirculating	0 None	PTC1
9	110-120 VAC, 50/60 Hz	P Positive	S Single-Pass/ Total Exhaust	L 1 Left	to
				R 1 Right	PTC7
				B 2 Both Sides	

CBI-U

Containment Barrier Isolator - Unidirectional



INTRODUCTION

CBI-U utilizes unidirectional/laminar airflow and facilitates the isolation of a product or process while providing the required conditions (ISO Class 5/ Grade A Environment) for a sterile/aseptic environment. This equipment provides a comprehensive range of personnel and product protection in addition to protection for the surrounding work areas and the environment.

It is factory-configured to operate at positive or negative pressure in single pass or recirculating airflow. The type of application dictates the operating parameters (pressure/airflow) of the CBI-U.

APPLICATIONS

- Pharmacy Compounding (Chemotherapy/TPN)
- Small-scale Potent Material Handling
- Aseptic Processing
- Sterility Testing
- Research and Development
- Cell Processing

KEY FEATURES

- Laminar / Unidirectional airflow that complies to standards for sterile product handling
- HEPA (H14) filters with a typical efficiency of > 99.999% at 0.3 microns provide superior ISO Class 5 air cleanliness (Grade A).
- Recovery Time to maintain ISO Class 5 environment is less than 60 seconds
- Class II Containment as per ISO 10648-2 leak tightness

STANDARD COMPLIANCE

- USP <797> and USP <800>
- FDA cGMP and EU GMP
- Class 2 Pressure-tested as per ISO 10648-2
- Air Quality: ISO Class 5 (BS EN ISO 14644-1) and EC GMP Grade A
- H14 filters: HEPA as per EN 1822 and ULPA as per IEST-RP-CC001.3

CBI-U AIRFLOW PATTERN

Ambient air is pulled through the inlet prefilter located on top of the isolator. Air from the top inlet and from work zone is pulled by the fan which creates a positive pressure on the plenum that creates downflow. The HEPA (H14) downflow filter creates a laminar and particle-free ISO Class 5 air cleanliness as per ISO 14644-1 (equivalent to Class 1 as per US Fed Std 209E) inside the isolator to protect the work material inside the main chamber and pass-thru. Air from the work zone and pass-thru is quickly purged out by the fan to keep the area clean. The fan pulls approximately 90% of the purged air back to the plenum and after passing through the HEPA (H14) downflow filter.

The high rate of airflow recirculation helps to prolong filter life and reduces the chances of ambient contaminants entering the work zone. For a recirculating model, approximately 10% of the purged air is exhausted through an HEPA-filter to prevent heat build-up inside

the isolator that can be detrimental to drug compounding. This exhausted air is replenished by ambient air coming from the top inlet prefilter and a filter with 80% efficiency for positive pressure model. For a Total Exhaust/Single-Pass Model, 100% of the air is exhausted out of the isolator.

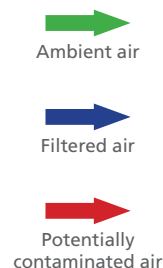

GENERAL SPECIFICATIONS

Containment Barrier Isolator - Unidirectional

		CBI-U-2G	CBI-U-3G	CBI-U-4G
Main Chamber Nominal Size (Width)		1.2 meter (4')	1.6 meter (5.2')	2.0 m (6.6')
Working Chamber Dimensions - Min (W x D x H)		1.2 m x 0.550 m x 0.77 m (4' x 1.8' x 2.6')	1.6 m x 0.55 m x 0.77 m (5.2' x 1.8' x 2.6')	2.0 m x 0.55 m x 0.77 (6.6' x 1.8' x 2.6')
Working Chamber Dimensions - Max (W x D x H)		1.2 m x 0.626 m x 0.84 m (4' x 2.1' x 2.9')	1.6 m x 0.626 m x 0.84 m (5.2' x 2.1' x 2.9')	2.0 m x 0.626 m x 0.84 m (6.6' x 2.1' x 2.9')
External Dimension (with one Pass Chamber) (W x D x H)	With Adjustable Base Stand (Min)	1.815 m x 0.92 m x 2.26 m	2.215 m x 0.92 m x 2.26 m	2.615 m x 0.92 m x 2.26 m
	With Adjustable Base Stand (Max)	1.815 m x 0.92 m x 2.56 m	2.22 m x 0.92 m x 2.56 m	2.615 m x 0.92 m x 2.56 m
Glove Port Height (Min)		1000 mm	1000 mm	1000 mm
Glove Port Height (Max)		1300 mm	1300 mm	1300 mm
Chamber Environment		ISO Class 5 all chambers (Grade A)		
Chamber Pressure		Factory-Configured Either Positive or Negative Pressure		
Airflow Type		Unidirectional/ Laminar Airflow Factory-Configured Recirculating or Single-Pass/Total Exhaust Model		
Filter Type - Chamber Inlet		HEPA (H14) Filter with Integral Mesh Guard and Gasket Seal		
Filter Efficiency - Chamber Inlet		99.995%		
Filter Type - Chamber Exhaust		HEPA (H14) Filter with Integral Mesh Guard and Gasket Seal		
Filter Efficiency - Chamber Exhaust		99.995%		
Lighting Level		≥ 500 Lux (6000 K)		
Sound Level		≤ 80 dBA		
Isolator Construction	Chamber	SS 316L		
	Service Housing	SS 304		
	Support Frame	SS 304		
Isolator Finish	Chamber Internal	≤ 0.4 Ra		
	Chamber External	≤ 0.6 Ra		
	Service Housing External	≤ 0.6 Ra		
	Support Frame	≤ 1.0 Ra		
Electrical Requirements	220-240 VAC, 50/60 Hz, 1Ø	CBI-U-2G8	CBI-U-3G8	CBI-U-4G8
(by Client)	110-120 VAC, 50/60 Hz, 1Ø	CBI-U-2G9	CBI-U-3G9	CBI-U-4G9
Compressed Air Requirement (by Client) If no on-board compressor	2 Bar-g Pressure at 5 L/sec	✓	✓	✓
Exhaust Duct Requirements (by Client) unless Integral Catalytic Converter is Included		10" Duct from Isolator to Outside		
Estimated Weight of Cabinet (1 PTC)		721 kg	900 kg	1121 kg
Estimated Weight of Cabinet (2 PTC)		851 kg	1030 kg	1209 kg
Net Weight			929 kg	1260 kg
Shipping Weight			979 kg	1320 kg
Shipping Dimension (W x D x H)		1550 X 950 X 1760 mm	2500 X 1080 X 2400 mm	3370 X 1100 X 2420 mm
Shipping Volume (Maximum)		2.59	6.48	8.97

ENGINEERING DRAWING

Containment Barrier Isolator - Unidirectional (CBI-U)

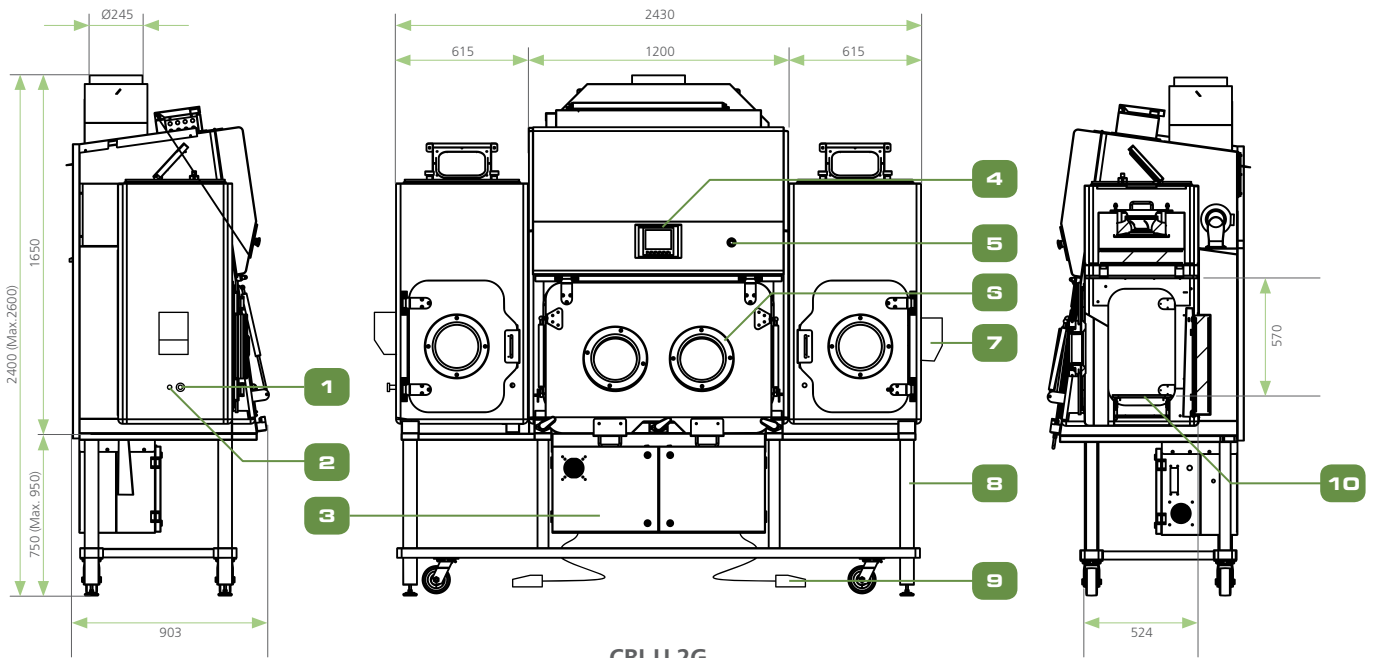
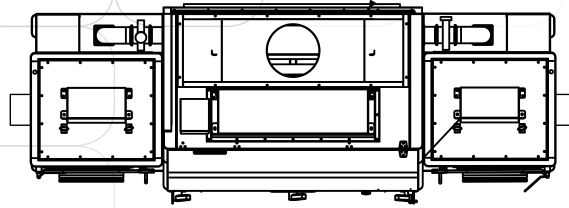

CBI-U 2G

- | | |
|--|------------------------------|
| 1. PAO Inject Port | 12. Manual Damper |
| 2. PAO Reading Port | 13. Inlet Prefilter, F6 |
| 3. Main Control Panel (Non-IP Rated) | 14. Electrical Control Panel |
| 4. Esco HMI (With Temperature and Humidity Monitoring) | 15. Supply Fan |
| 5. Emergency Switch | 16. Supply Filter, H14 |
| 6. Polypropylene Round Glove Ports | 17. Fluorescent Lamp |
| 7. BioVap Nozzle Housing (Optional) | 18. 2nd Exhaust Filter, H14 |
| 8. Fixed Height Support Stand | 19. Exhaust Fan |
| 9. Foot Pedal for Inner Door | 20. IV Bar |
| 10. Sliding Tray | 21. Exhaust Filter, H14 |
| 11. Exhaust Collar (Ø245mm) | |

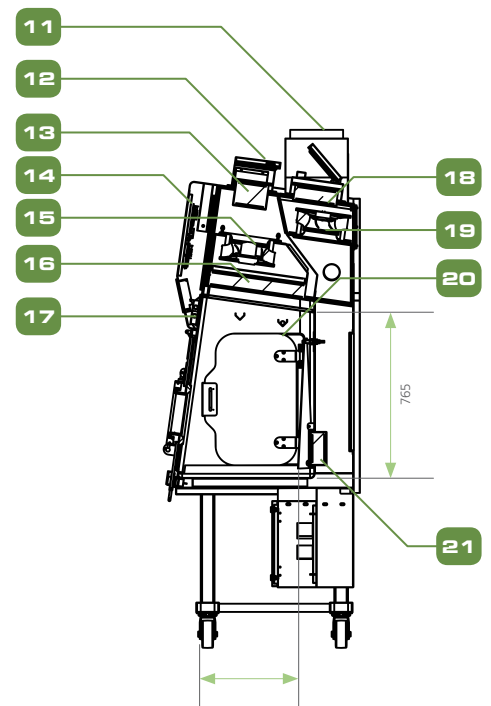

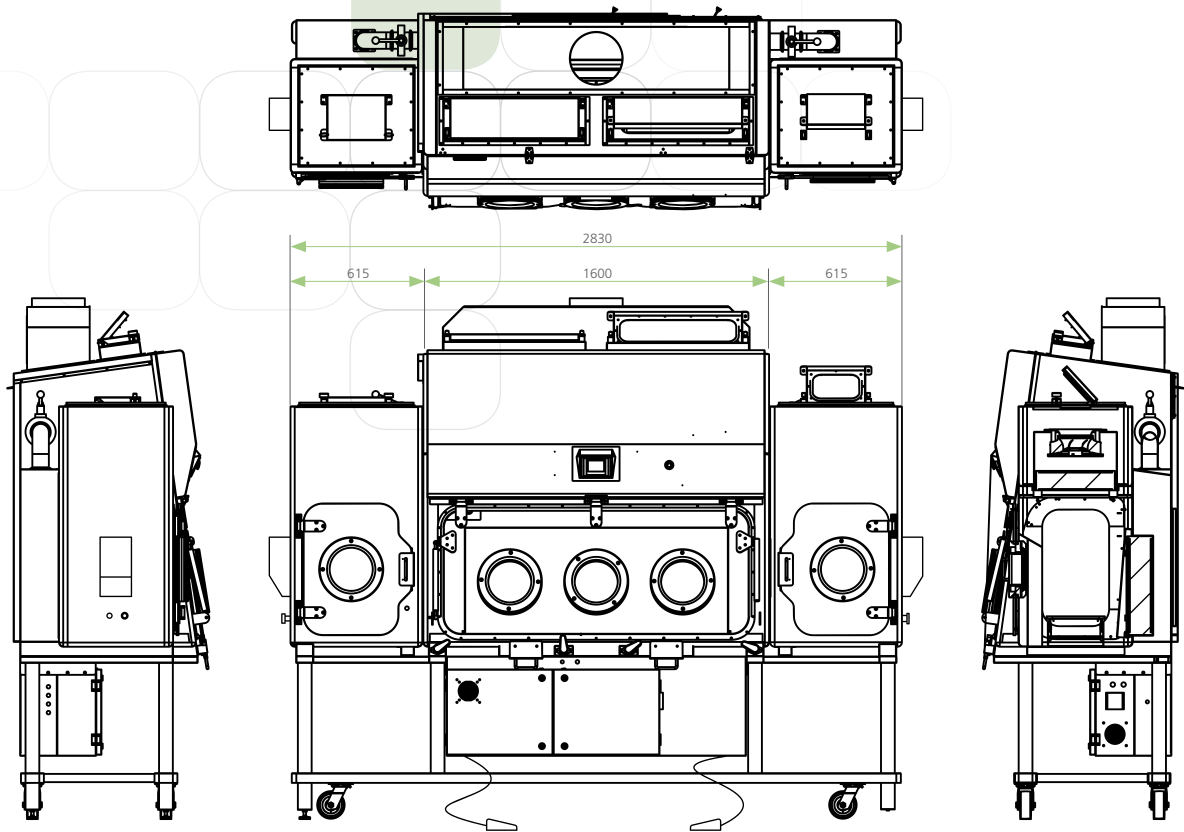

CBI-U 3G

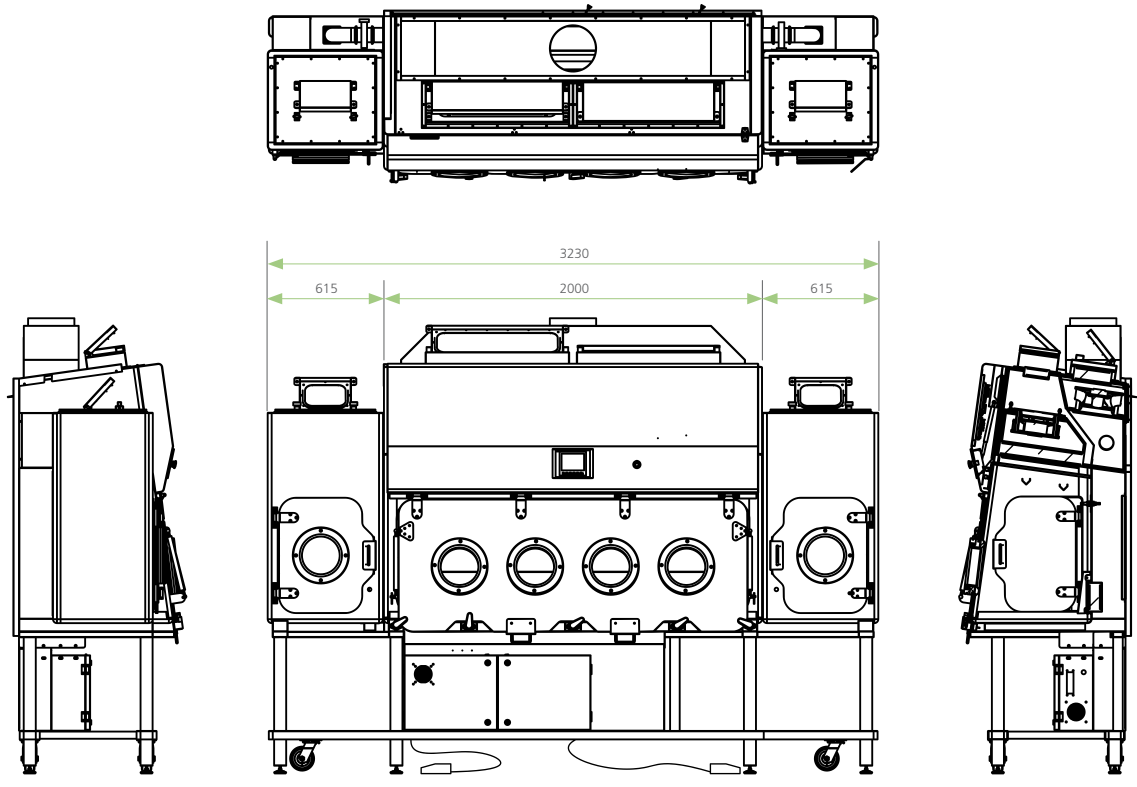

CBI-U 4G

CBI-T

Containment Barrier Isolator - Turbulent



INTRODUCTION

CBI-T utilizes turbulent airflow and facilitates the isolation of a product or process while providing the required condition for handling potent powder compounds.

In CBI-T, a supply filtered air is introduced into the chamber that mixes with and dilutes airborne contaminants, thus reducing the concentration within the environment. Most contaminants are ultimately removed from the environment through the air exhaust system. Contamination removal takes longer to achieve because the air turbulence keeps particles suspended and the dilution process is dependent on the volume of air cycling through the space.

APPLICATIONS

- Potent Powder Handling
- HPAPI QC Testing
- Research and Development

KEY FEATURES

- Utilizes turbulent airflow for dilution of airborne compounds, thus reducing concentration in the environment
- Fully welded Stainless steel 316L internal chambers with Stainless steel 304 external housing
- Optional FDA-approved hydraulic stand that can be raised and lowered by the operator for optimum ergonomic comfort
- Esco HMI controller supervises all functions and monitors airflow and pressures in real-time.
- Cost-effective solution for potent powder handling

STANDARD COMPLIANCE

- Air Quality: ISO Class 7 (BS EN ISO 14644-1)
- Class 2 Containment as per ISO 10648-2

CBI-T AIRFLOW PATTERN

Ambient air is pulled through the inlet prefilter located in front of the isolator. Air from the inlet is pulled by the fan towards the push-push filter to the pass through chamber. The downflow filter creates a turbulent airflow in the pass through chamber. Filtered air from the pass through chamber is then pulled towards the push push filter and transferred to the main chamber. This filtered air also creates a turbulent airflow in the main chamber. Air is then exhausted out in the top portion of the isolator after passing another stage of filtration.

The high rate of airflow circulation helps to prolong filter life and reduces the chances of ambient contaminants entering the work zone. Exhausted air is replenished by ambient air coming from the inlet prefilter.

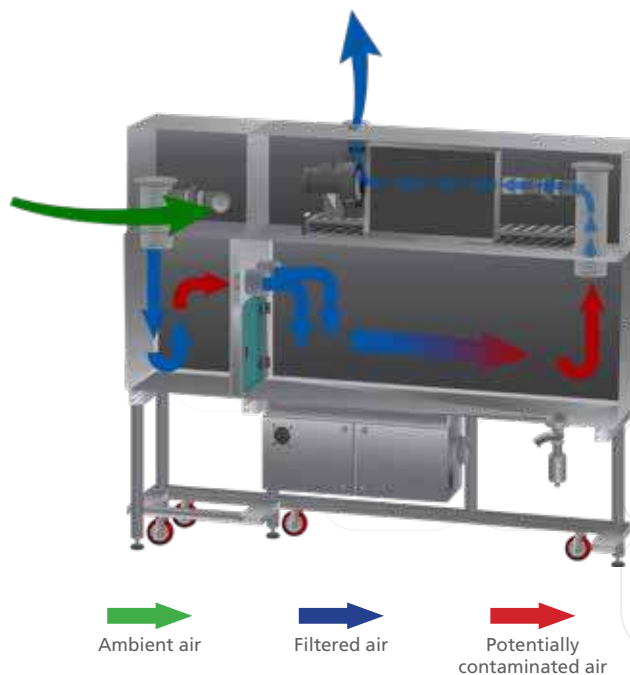

GENERAL SPECIFICATIONS

Containment Barrier Isolator - Turbulent

		CBI-T-2G	CBI-T-3G	CBI-T-4G
Main Chamber Nominal Size (mm)		1.2 meter (4')	1.6 meter (5.2')	2.00 meter (6.6')
Process Chamber External Dimension - (W x D x H)		1.20 m x 0.64 m x 0.84 m (4' x 2.1' x 2.8')	1.60 m x 0.64 m x 0.84 m (5.2' x 2.1' x 2.8')	2.0 m x 0.64 m x 0.84 (6.6' x 2.1' x 2.8')
Pass-through Chamber External Dimension - (W x D x H)		0.6 m x 0.52 m x 0.84 m (2' x 1.7' x 2.8')		
External Dimensions with 1 Pass Chamber - (W x D x H)		1.83 m x 0.70 m x 2.28 m (6' x 2.3' x 7.5')	2.23 m x 0.70 m x 2.28 m (7.3' x 2.3' x 7.5')	2.63 m x 0.70 x 2.28 m (8.6' x 2.3' x 7.5')
Glove Port Diameter (mm)		200 mm x 300 mm		
Glove Port Quantity		2	3	4
Chamber Pressure		Negative Pressure		
Airflow Type		Turbulent Flow		
Chamber Environment		ISO Class 8 (Grade D)		
Filter Type - Inlet		HEPA (H14) Cartridge Filter		
Filter Efficiency - Inlet		99.98%		
Filter Type - Exhaust		HEPA (H14) Cartridge Filter		
Filter Efficiency - Exhaust		99.98%		
Lighting Level		>650 Lux		
Sound Level		≤ 80 dBA		
Air Change Per Hour	Process Chamber	48	36	29
	Pass Chamber	61	61	61
Air Volume (m ³ /h)	Process Chamber	31	31	31
	Pass Chamber	16	16	16
Isolator Construction	Main Body	SS 316L		
	Internal Chambers	SS 316L		
	Support Frame and Service Housing	SS 304		
Electrical Requirements (by Client)	230 VAC, 50/60 Hz, 1Ø	CBI-T-2G8	CBI-T-3G8	CBI-T-4G8
	110-120 VAC, 50/60 Hz, 1Ø	CBI-T-2G9	CBI-T-3G9	CBI-T-4G9
Compressed Air Requirement (by Client)	2 Bar-g Pressure at 5 L/sec	2 Bar		
Exhaust Duct requirements (by Client)		4" (101.6mm)		
Net Weight		TBD	TBD	TBD
Shipping Weight		TBD	TBD	TBD
Shipping Dimension (W x D x H)		TBD	TBD	TBD
Shipping Volume (Maximum)		TBD	TBD	TBD

ENGINEERING DRAWING

Containment Barrier Isolator - Turbulent (CBI-T)

CBI-T 2G

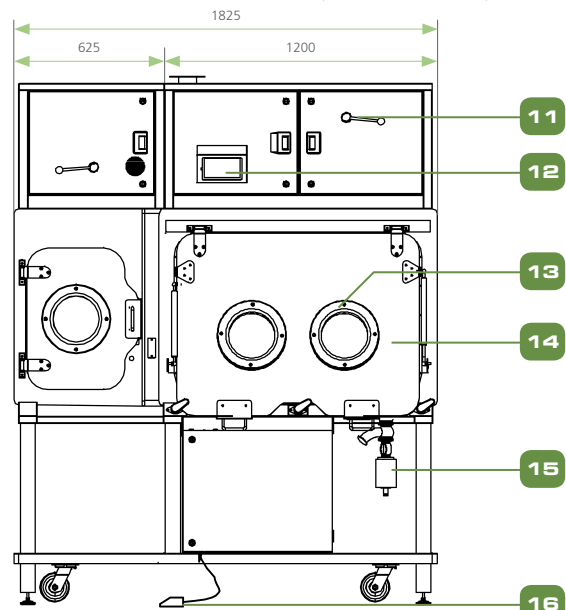
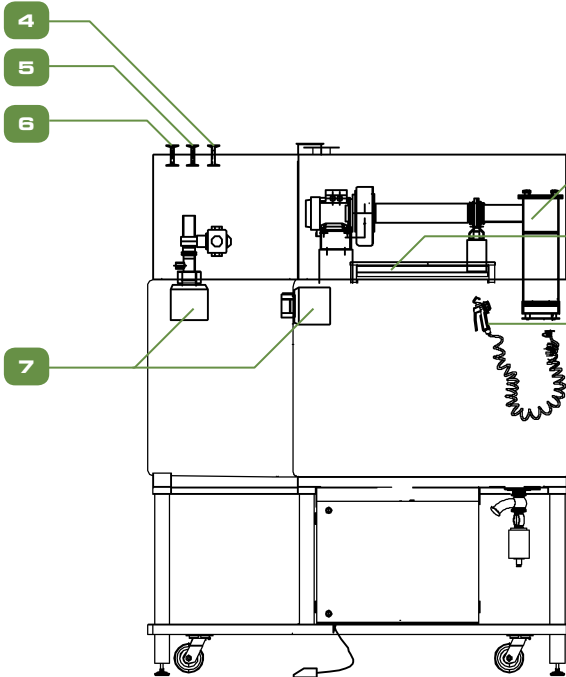
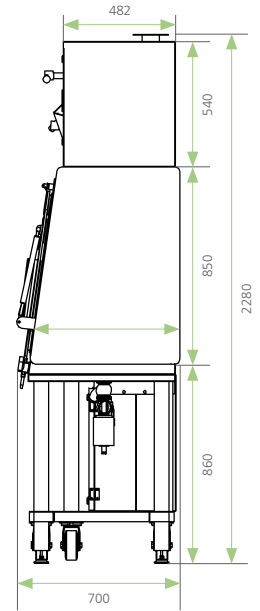
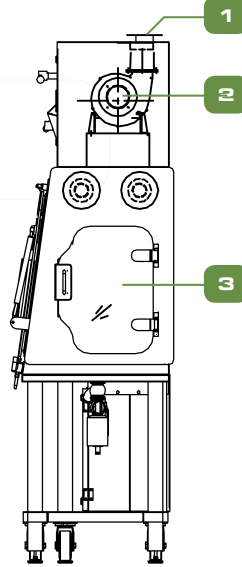
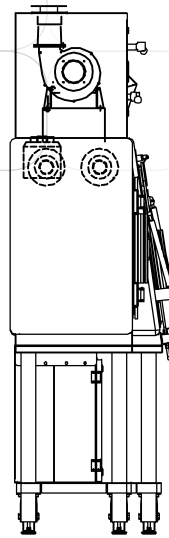
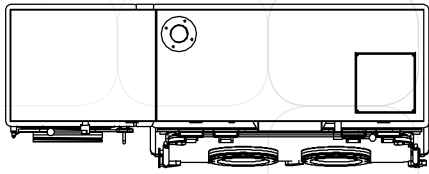

16

- | | | | |
|--|---------------------------------------|---|---|
| 1. Exhaust Connection | 6. N2 Purge | 12. Esco HMI | 17. Exhaust Connection |
| 2. Exhaust Fan Assembly | 7. Canister HEPA H14 Filter Air Inlet | 13. Polypropylene Glove Ports | 18. Exhaust Fan Assembly |
| 3. Pass Chamber Inner Door Inflatable Seal | 8. Exhaust Filter Assy Push Push | 14. Process Chamber, 316 ST ST | 19. Pass Chamber Inner Door Inflatable Seal |
| 4. WIP Inlet | 9. Light Fitting | 15. 1.5" Ball Valve for Drain Connection (Optional) | |
| 5. Compressed Air Inlet | 10. WIP Spray Gun (Optional) | 16. Foot Pedal for Inner Door | |
| | 11. Manual Valve | | |

CBI-T 4G

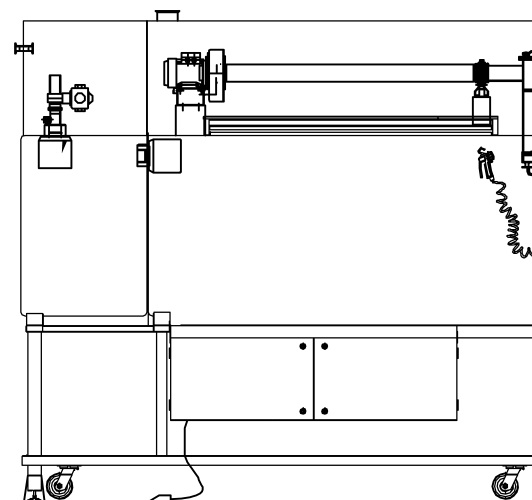
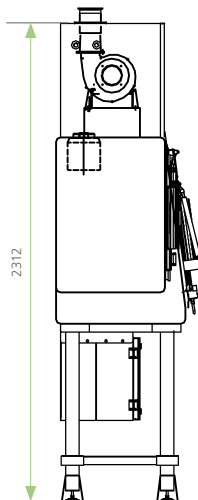

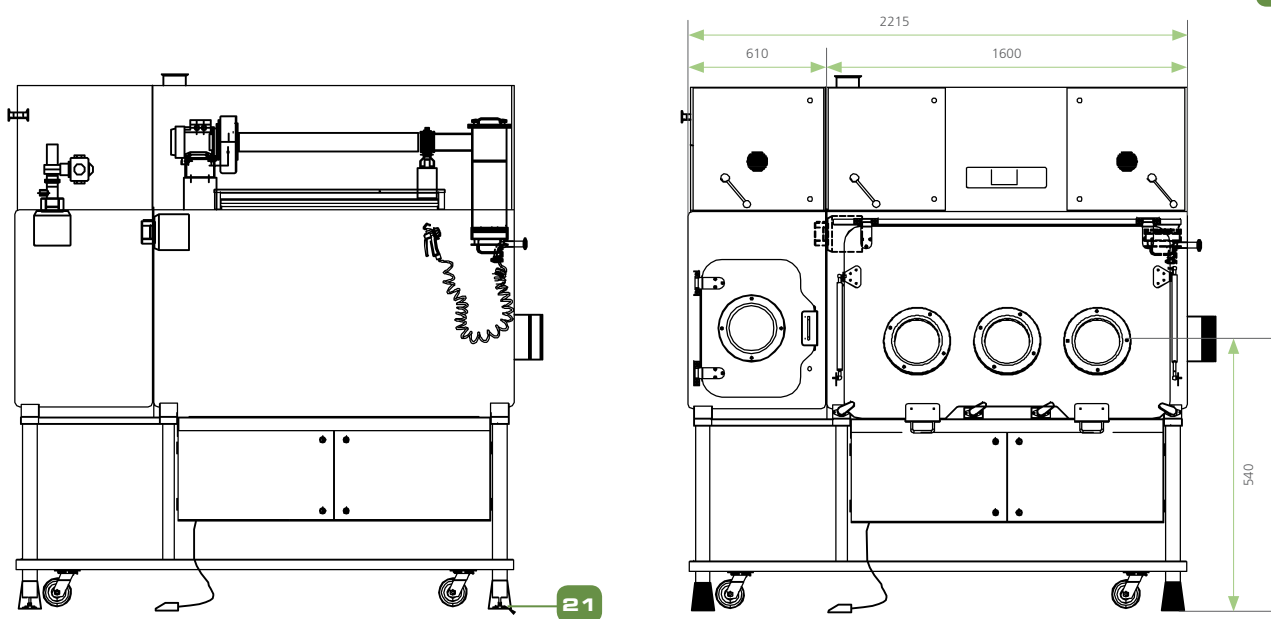
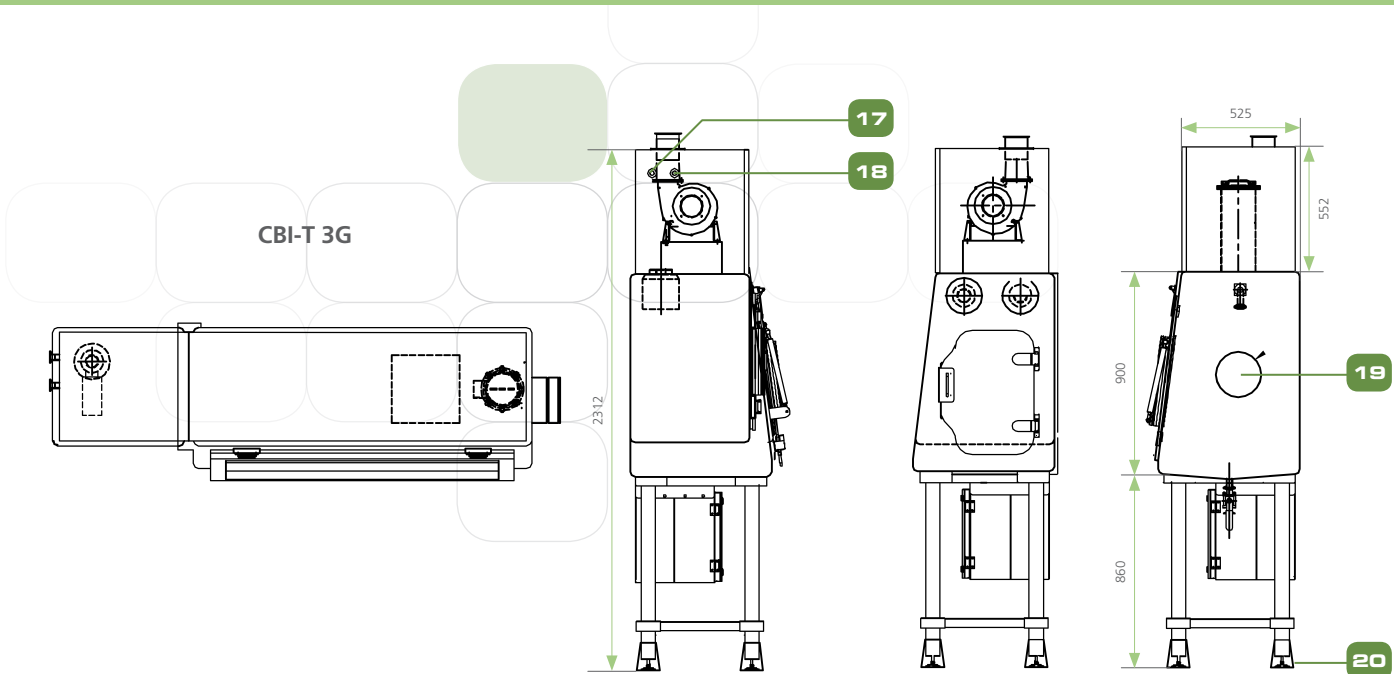

- 17. Compressed Air (Optional)
- 18. N2 Purge (Optional)
- 19. Ø200 Bag Out Port Single Piece Gauntlets (Optional)
- 20. Feet Vanity Cover
- 21. Levelling Feet

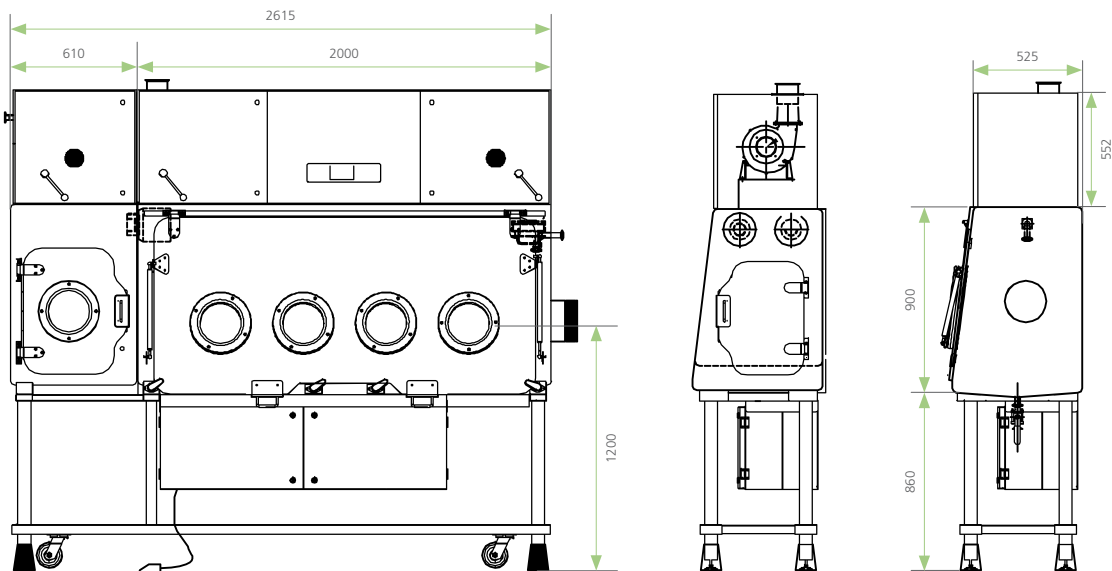

CBI-III

Containment Barrier Isolator – Class III Biosafety Cabinet

INTRODUCTION

CBI-III offers the highest level of operator, product, and environmental protection from infectious/biohazardous aerosols and is suitable for microbiological work with agents assigned to biosafety levels 1,2,3, or 4. It is designed for an absolute level of containment, it is frequently used for work involving the deadliest biohazards, bacteria, viruses, and microorganisms.

CBI-III is configured to operate at a minimum of -125 Pa to provide adequate containment for handling highly pathogenic and lethal biological agents.

APPLICATIONS

- Laboratory containment for handling biological agents of up to level 4
- Virus and vaccine production
- Research and development

KEY FEATURES

- Fully welded Stainless steel 316L internal chambers with Stainless steel 304 external housing
- Exhaust air is double-filtered through high-quality ULPA filters (per IEST-RP-CC-001.3) with typical efficiency of >99.999% for 0.1 to 0.3 micron particles, better than HEPA filters.
- An integrated pass-through with interlocking doors permits materials transfer without risk of contamination
- Single-piece, leak-tested glove assemblies which guarantee maximum protection.



STANDARD COMPLIANCE

- BS EN 12469
- Air Quality: ISO Class 5 (BS EN ISO 14644-1) and EC GMP Grade A
- H14 filters: HEPA as per EN 1822 and ULPA as per IEST-RP-CC001.3

CBI-III AIRFLOW PATTERN

Ambient air is pulled through the inlet prefilter located on top of the isolator. Air from the top inlet and from work zone is pulled by the fan which creates a positive pressure on the plenum that creates downflow. The HEPA (H14) downflow filter creates a laminar and particle-free ISO Class 5 air cleanliness as per ISO 14644-1 (equivalent to Class 1 as per US Fed Std 209E) inside the isolator to protect the work material inside the main chamber and pass-thru. Air from the work zone and pass-thru is quickly purged out by the fan to keep the area clean. The fan pulls approximately 90% of the purged air back to the plenum and after passing through the HEPA (H14) downflow filter.

The high rate of airflow recirculation helps to prolong filter life and reduces the chances of ambient contaminants entering the work zone. For a recirculating model, approximately 10% of the purged air is exhausted through an HEPA-filter to prevent heat build-up inside

the isolator that can be detrimental to drug compounding. This exhausted air is replenished by ambient air coming from the top inlet prefilter and a filter with 80% efficiency for positive pressure model. For a Total Exhaust/Single-Pass Model, 100% of the air is exhausted out of the isolator.

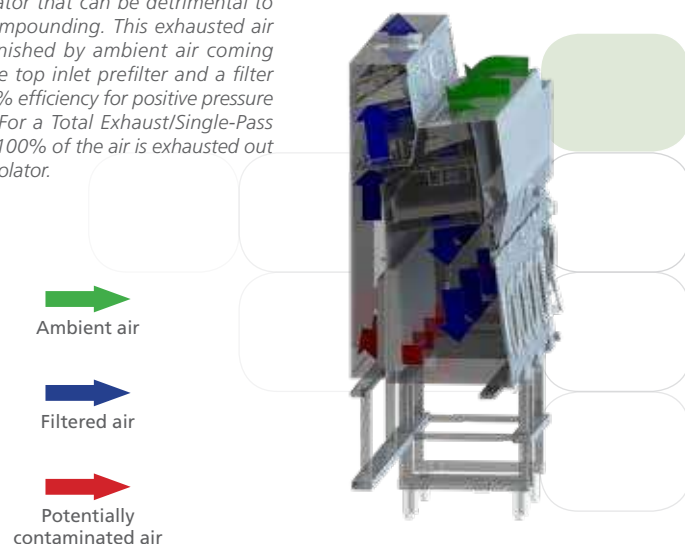

GENERAL SPECIFICATIONS

Containment Barrier Isolator - Class III Biosafety Cabinet

		CBI-III-2G	CBI-III-3G	CBI-III-4G
Main Chamber Nominal Size (Width)		1.2 meter (4')	1.6 meter (5.2')	2.0 m (6.6')
Working Chamber Dimensions - Min (W x D x H)		1.2 m x 0.55 m x 0.77 m (4' x 1.8' x 2.6')	1.6 m x 0.55 m x 0.77 m (5.2' x 1.8' x 2.6')	2.0 m x 0.55 m x 0.77 (6.6' x 1.8' x 2.6')
Working Chamber Dimensions - Max (W x D x H)		1.2 m x 0.63 m x 0.84 m (4' x 2.1' x 2.9')	1.6 m x 0.63 m x 0.84 m (5.2' x 2.1' x 2.9')	2.0 m x 0.63 m x 0.84 m (6.6' x 2.1' x 2.9')
External Dimension (with one Pass Chamber) (W x D x H)	With Adjustable Base Stand (Min)	1.82 m x 0.92 m x 2.55 m (6.0' x 3.0' x 8.4')	2.22 m x 0.92 m x 2.55 m (7.3' x 3.0' x 8.4')	2.62 m x 0.92 m x 2.55 m (8.6' x 3.0' x 8.4')
	With Adjustable Base Stand (Max)	1.82 m x 0.92 m x 2.85 m (6.0' x 3.0' x 9.4')	2.22 m x 0.92 m x 2.85 m (7.3' x 3.0' x 9.4')	2.62 m x 0.92 m x 2.85 m (8.6' x 3.0' x 9.4')
External Dimension -Small Pass-through Chamber (W x D x H)		0.60 x 0.52 x 0.76 m		
Glove Port Height (Min)		1000 mm	1000 mm	1000 mm
Glove Port Height (Max)		1300 mm	1300 mm	1300 mm
Chamber Environment		ISO Class 5 all chambers (Grade A)		
Pre-filter	Process Chamber	G4, polyester media		
	Pass-through Chamber	G4, polyester media		
Filter Type - Chamber Inlet		HEPA (H14) Filter with Integral Mesh Guard and Gasket Seal		
Filter Efficiency - Chamber Inlet		99.995% MPPS		
Filter Type - Chamber Exhaust		HEPA (H14) Filter with Integral Mesh Guard and Gasket Seal		
Filter Efficiency - Chamber Return and Exhaust		99.995% MPPS		
Lighting Level		≥ 500 Lux (6000 K)		
Sound Level		≤ 80 dBA		
Airflow Type		Unidirectional/ Laminar Airflow		
Chamber Operating Pressure		negative 125 Pa		
Isolator Construction	Chamber	SS 316L		
	Service Housing	SS 304		
	Support Frame	SS 304		
Isolator Finish	Chamber Internal	≤ 0.4 Ra		
	Chamber External	≤ 0.6 Ra		
	Service Housing External	≤ 0.6 Ra		
	Support Frame	≤ 1.0 Ra		
Electrical Requirements	220-240 VAC, 50/60 Hz, 1Ø	CBI-3-2G8	CBI-3-3G8	CBI-3-4G8
(by Client)	110-120 VAC, 50/60 Hz, 1Ø	CBI-3-2G9	CBI-3-3G9	CBI-3-4G9
Compressed Air Requirement (by Client) If no on-board compressor	2 Bar-g Pressure at 5 L/sec	✓	✓	✓
Exhaust Duct Requirements (by Client) unless Integral Catalytic Converter is Included		10 " Duct from Isolator to Outside		
Air Change per Hour		1570 ACH	1570 ACH	1570 ACH
Volumetric Flow Rate		916 cmh	1225 cmh	1532 cmh
Downflow Velocity		0.4 m/s		
Net Weight		TBD	TBD	TBD
Shipping Weight		TBD	TBD	TBD
Shipping Dimension (W x D x H)		TBD	TBD	TBD
Shipping Volume (Maximum)		TBD	TBD	TBD

ENGINEERING DRAWING

Containment Barrier Isolator - Class III BSC (CBI-III)

CBI-III 2G

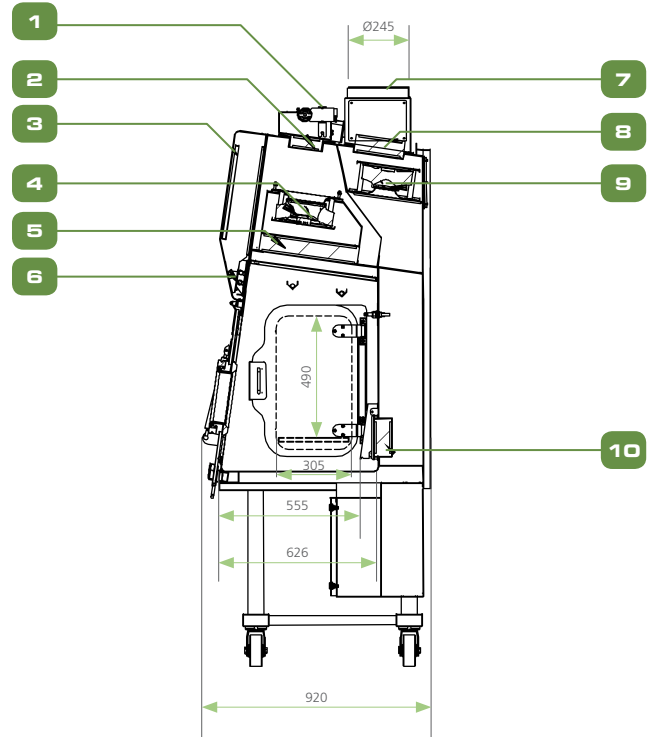
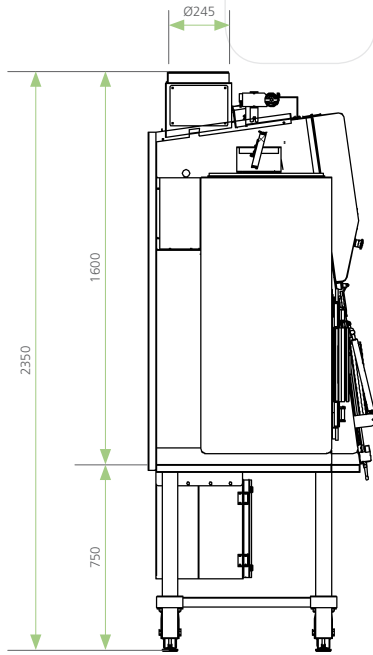
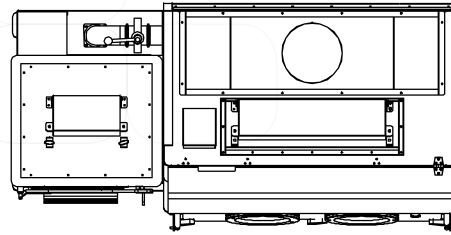

1. Automated Damper
2. Inlet Pre-Filter, F6
3. Electrical Control Panel
4. Supply Fan
5. Supply Filter, H14
6. Fluorescent Lamp
7. Exhaust Collar (10")
8. Filter, F6
9. Exhaust Fan
10. Exhaust Filter, H14
11. Esco HMI
12. Emergency Switch
13. Polypropylene Glove Ports
14. Levelling Feet
15. Caster Wheels

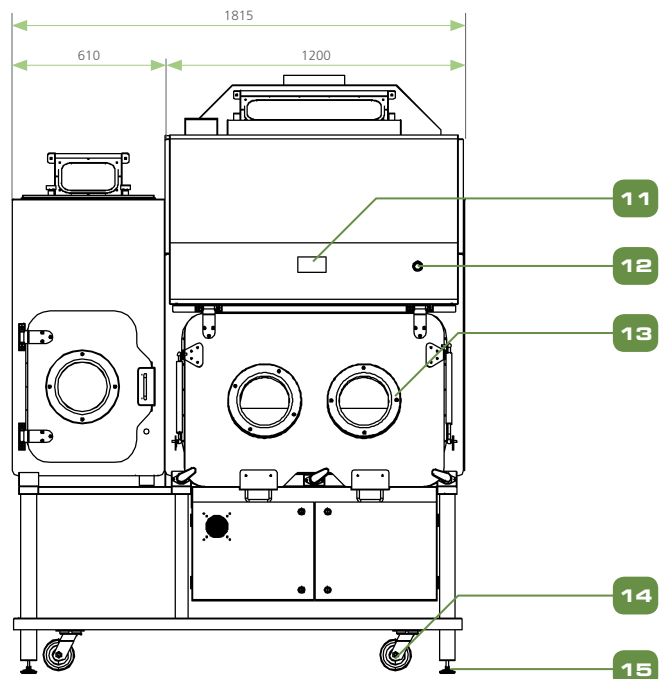

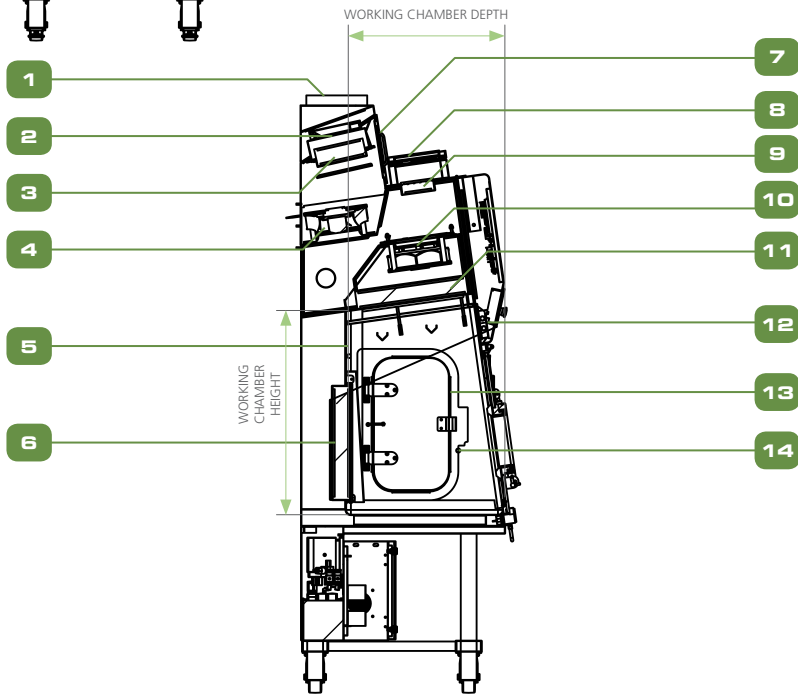
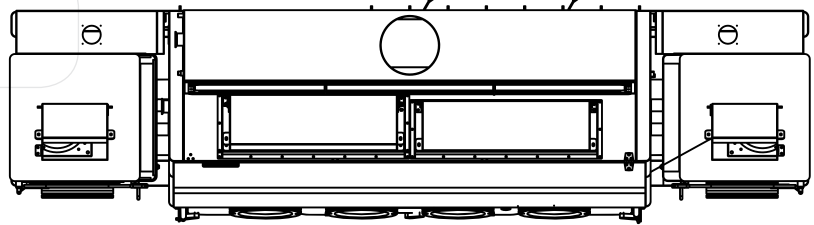
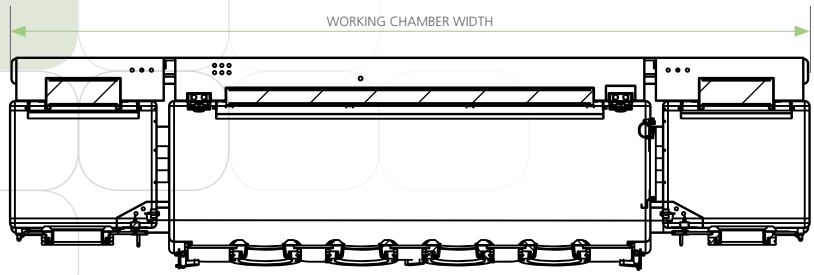
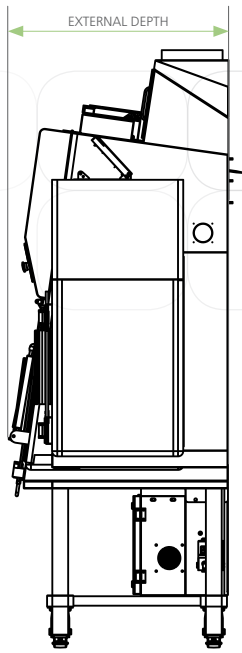

1. Exhaust Collar
2. Manual Exhaust Damper
3. Second Stage Exhaust Filter
4. Exhaust Blowers
5. UV Lamp
6. First Stage Exhaust Filter
7. Front Access - Blower and Filter
8. Supply Damper
9. Pre-Filter, H11
10. Supply Blower
11. Supply Filter
12. Fluorescent Lamp
13. Inflatable Seal Inner Doors
14. Door Push Button
15. Decon Port (Out) (Optional)
16. Decon Port (In) (Optional)
17. Esco HMI
18. Safety Glass
19. Electrical Control Panel
20. Static/Dynamic Pass Through Option
21. Onboard Compressor Option

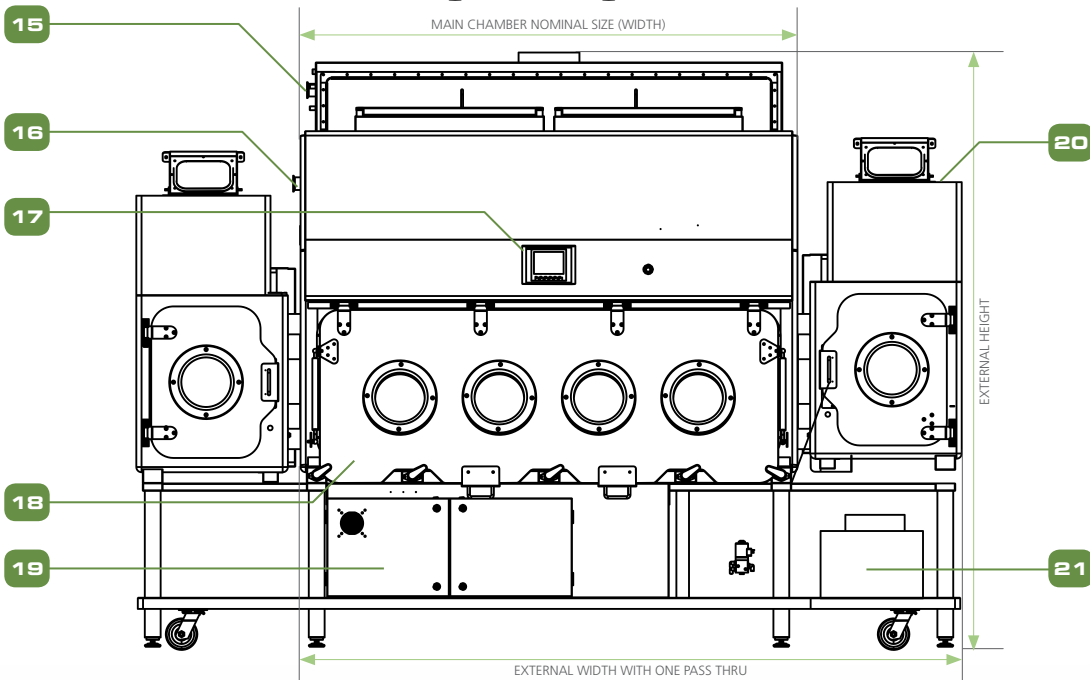



CBI-H

Containment Barrier Isolator – Hybrid (Convertible Class III/Class I Biosafety Cabinet)

INTRODUCTION

CBI-H builds on Esco Pharma's success of CBI-III. It allows operators to work via a removable glove visor to convert the cabinet and function as a Class III or a Class I Biosafety Cabinet as per EN 12469 standards. In BSC Class III mode, the operator works through a glove port attached to a removable panel. It can be converted to a BSC Class I by removing the closure panel and attaching a blanking plate over the inlet HEPA filter.

To ensure maximum performance, commissioning and preventive maintenance of the cabinet must be done in both modes.

APPLICATIONS

- Laboratory containment for handling biological agents of up to level 4
- Research and Development

KEY FEATURES

- Designed to operate as a Class III BSC convertible to Class I BSC, or vice versa.
- In Class III BSC mode, access to the work zone is through the gloves/gauntlets set into a removable panel.
- Converted to Class I BSC by removing the panel, and closing the air inlets on both sides.
- Fully stainless steel SS 316L interior and SS 304 exterior
- Easy to clean inside and out; easy to maintain

STANDARD COMPLIANCE

- BS EN 12469
- Air Quality: ISO Class 5 (BS EN ISO 14644-1) and EC GMP Grade A
- HEPA filters: H14
- Electrical wiring designed to IEC 61010-1

CBI-H AIRFLOW PATTERN

Class I BSC Mode

Cabinet can be converted to a Class I BSC Mode by simply removing the front glove port attachment panel. Ambient air is pulled inside the work zone and is exhausted out of the cabinet by passing through a HEPA (H14) filter prior to exhaust.

Class III BSC Mode

Ambient air is pulled through the inlet pre-filter and HEPA (H14) filter located at the both sides of the cabinet. The HEPA (H14) filter provides particle-free ISO Class 5 air cleanliness as per ISO 14644-1. Air from both the passthrough chamber and main chamber is pulled to the top portion through a HEPA (H14) filter and is 100% exhausted out of the cabinet through a dedicated ducting system.

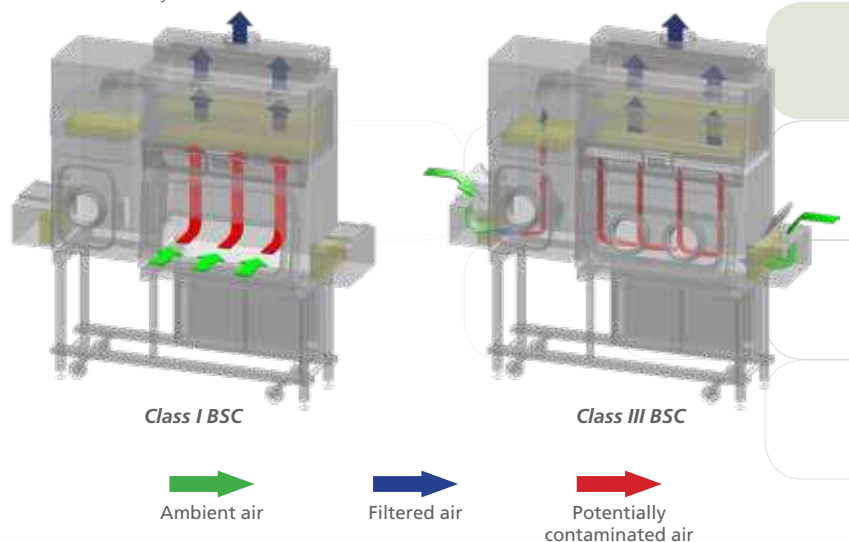

GENERAL SPECIFICATIONS

Containment Barrier Isolator - Hybrid
(Convertible Class III/Class I Biosafety Cabinet)

		CBI-H-2G	CBI-H-3G	CBI-H-4G
Main Chamber Nominal Size (Width)		1.2 meter (4')	1.6 meter (5.2')	2.0 m (6.6')
Working Chamber Dimensions - Min (W x D x H)		1.20 m x 0.55 m x 0.77 m (3.9' x 1.8' x 2.5')	1.60 m x 0.55 m x 0.77 m (5.2' x 1.8' x 2.5')	2.0 m x 0.55 m x 0.77 m (6.6' x 1.8' x 2.5')
Working Chamber Dimensions - Max (W x D x H)		1.20 m x 0.63 m x 0.84 m (3.9' x 2.1' x 2.8')	1.60 m x 0.63 m x 0.84 m (5.2' x 2.1' x 2.8')	2.0 m x 0.63 m x 0.84 m (6.6' x 2.1' x 2.8')
External Dimension (with one Pass Chamber) (W x D x H)	With Adjustable Base Stand (Min)	1.82 m x 0.92 m x 2.55 m (6.0' x 3.0' x 8.4')	2.22 m x 0.92 m x 2.55 m (7.3' x 3.9' x 8.4')	2.62 m x 0.92 m x 2.55 m (8.6' x 3.0' x 8.4')
	With Adjustable Base Stand (Max)	1.82 m x 0.92 m x 2.85 m (6.0' x 3.0' x 9.4')	2.22 m x 0.92 m x 2.85 m (7.3' x 3.9' x 9.4')	2.62 m x 0.92 m x 2.85 m (8.6' x 3.0' x 9.4')
External Dimension of Pass-through Chamber (W x D x H)		0.62 x 0.66 x 0.58 m		
Glove Port Height (Min)		1200 mm	1200 mm	1200 mm
Glove Port Height (Max)		1500 mm	1500 mm	1500 mm
Chamber Environment		ISO Class 5 all chambers (Grade A)		
Airflow	Class III	Turbulent		
	Class I	Unidirectional (Positive)		
Pre-filter	Process Chamber	G4, polyester media		
	Pass-through Chamber	G4, polyester media		
Filter Type - Chamber Inlet		HEPA (H14) Filter with Integral Mesh Guard and Gasket Seal		
Filter Efficiency - Chamber Inlet		99.995% MPPS		
Filter Type - Chamber Exhaust - 1st Stage		HEPA (H14) Filter with Integral Mesh Guard and Gasket Seal		
Filter Type - Chamber Exhaust - 2nd Stage		HEPA (H14) Filter with Integral Mesh Guard and Gasket Seal or Carbon Filter		
Filter Efficiency - Chamber Exhaust - 1st Stage		99.995% MPPS		
Filter Efficiency - Chamber Exhaust - 2nd Stage		99.995% MPPS		
Lighting Level		≥ 500 Lux (6000 K)		
Sound Level		≤ 80 dBA		
Isolator Construction	Chamber	SS 316L		
	Service Housing	SS 304		
	Support Frame	SS 304		
Isolator Finish	Chamber Internal	≤ 0.4 Ra		
	Chamber External	≤ 0.6 Ra		
	Service Housing External	≤ 0.6 Ra		
	Support Frame	≤ 1.0 Ra		
Electrical Requirements	220-240 VAC, 50/60 Hz, 1Ø	CBI-H-2G8	CBI-H-3G8	CBI-H-4G8
(by Client)	110-120 VAC, 50/60 Hz, 1Ø	CBI-H-2G9	CBI-H-3G9	CBI-H-4G9
Compressed Air Requirement (by Client) If no on-board compressor	2 Bar-g Pressure at 5 L/sec	✓	✓	✓
Exhaust Duct Requirements (by Client) unless Integral Catalytic Converter is Included		10" Duct from Isolator to Outside		
Net Weight		TBD	TBD	TBD
Shipping Weight		TBD	TBD	TBD
Shipping Dimension (W x D x H)		TBD	TBD	TBD
Shipping Volume (Maximum)		TBD	TBD	TBD

ENGINEERING DRAWING

Containment Barrier Isolator - Hybrid (Convertible Class III/Class I BSC) (CBI-H)

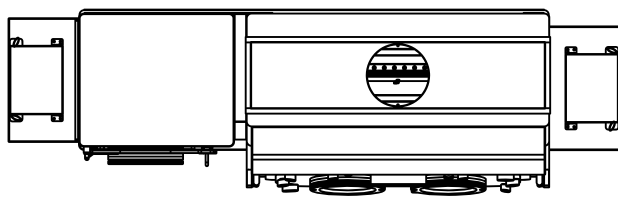
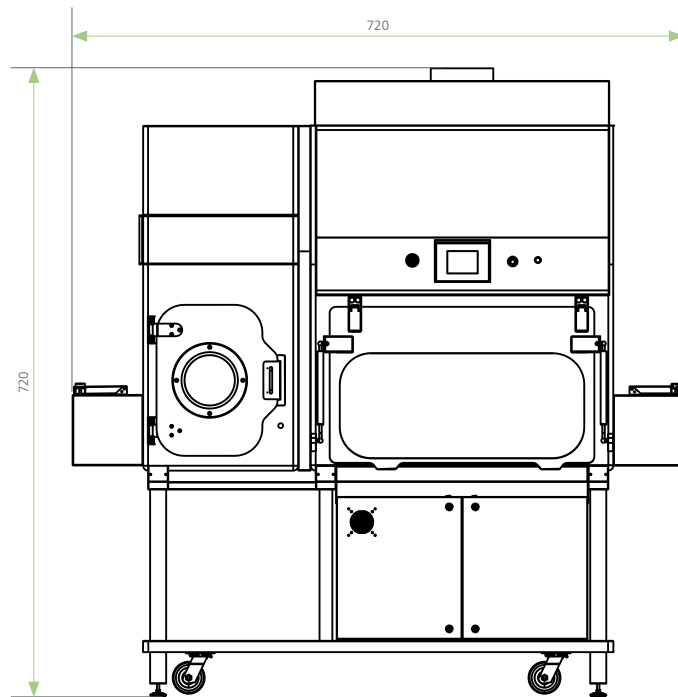
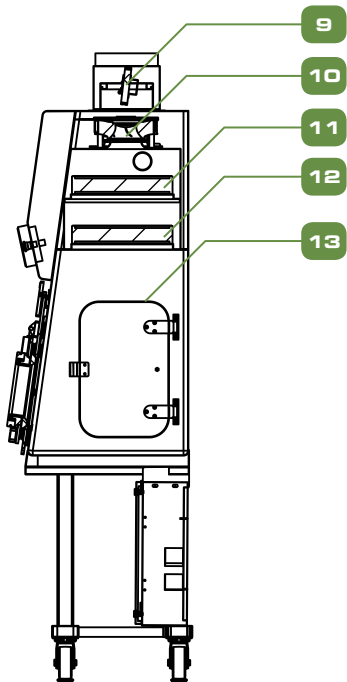
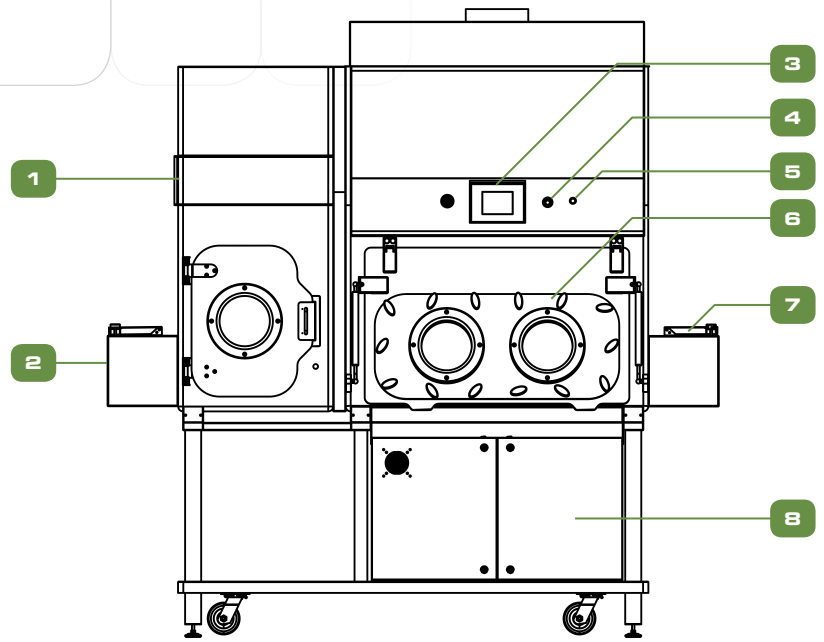
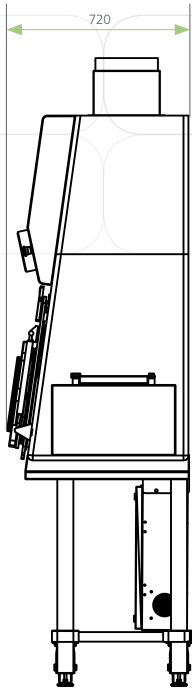

- 1. Exhaust Filter Housing
- 2. PTC Inlet
Open: BSC Class III Operation
Close: BSC Class I Operation
- 3. Esco HMI
- 4. Reset Button
- 5. Emergency Stop
- 6. Removable Glove Port
Installed: BSC Class III Operation
Removed: BSC Class I Operation
- 7. Chamber Air Inlet
Open: BSC Class III Operation
Close: BSC Class I Operation
- 8. Electrical / Pneumatic Panel
- 9. 1st Exhaust Filter
- 10. 2nd Exhaust Filter
- 11. Exhaust Blower
- 12. Exhaust Damper
- 13. Inflatable Seal
- 14. Inner Door

LIST OF OPTIONS FOR CBI MODELS

				CBI-U	CBI - T	CBI-III	CBI-H
Pass Chamber (Outer Door is always with static seals)		Inner Door	Type of Seal for Inner Door				
	Small Static (without gloves)	Internal -Vertical Sliding	Inflatable Seal	✓	✓	✓	✓
		Internal - Manual	Static Seal	✓			
	Small Dynamic (without gloves)	Internal -Vertical Sliding	Inflatable Seal	✓	✓	✓	✓
	Big Dynamic (with gloves)	Manual	Inflatable Seal	✓	✓	✓	✓
			Static Seal	✓			
	Big Static (with gloves)	Manual	Inflatable Seal			✓	✓
Inflatable Seal					✓	✓	
Big Static (without gloves)		Inflatable Seal			✓	✓	
4" Split Butterfly Valve (for powder discharge of powder below isolator chamber)				✓	✓		
Adjustable Hydraulic Stand (based on operator ID input)				✓		✓	✓
Exhaust Box (with automated dampers with inflatable seals or manual with valve)				✓		✓	✓
Anti-blow back damper box				✓	✓		✓
Automated Pressure Hold Test	with Client Supplied Compressed Air			✓	✓	✓	✓
	with On-board Air Compressor			✓	✓	✓	✓
Bag Welder with Table Bag-out Port				✓	✓	✓	
Bio Dunk Tank Bag Out Port						✓	✓
Mobile Biodecontamination BioVap™				✓		✓	✓
Carbon Filter				✓			
Convertible to Class 1 cabinet							✓
Integration of small scale aseptic or potent tablet/capsule etc...				✓	✓	✓	✓
Double-sided access					✓	✓	✓
Manual Drain Ball Valve (for client controlled CIP/WP) must order with inner pass-through inflatable sealed doors.				✓	✓		
Electrical Outlet (IP66)	IP 66			✓	✓	✓	✓
	ATEX Zone 1/21 (only for internal environment)			✓	✓		✓
ATEX rating up to zone 1/21 internally only (ATEX fan, "IS" signals for internal door sensor/ push button)				✓	✓		
Glove Leak Tester				✓	✓	✓	✓
Formalin Vaporizer (auto neutralization and purge cycle)				✓		✓	✓
H2O2 Monitoring (sensor is not integrated with HMI)				✓		✓	✓
Liquid Water Entry / Exit Ports						✓	✓

LIST OF OPTIONS FOR CBI MODELS

		CBI-U	CBI - T	CBI-III	CBI-H
N2 Purge for Process Chamber			✓		
Ø250 mm Product Waste Bag Out Ports /				✓	
Battery option to maintain EM interlock during power outage or E Stop		✓	✓	✓	✓
Particle Counter	Portable Particle Counter (Non-viable)	✓		✓	✓
	Microbial Air Samples (Viable Particle Counter)	✓		✓	✓
Product Waste Entry / Exit Ports		✓			✓
RTPØ 105, 190, 270 - Alpha		✓	✓	✓	✓
RTPØ 105, 190, 270 - Beta Canister		✓		✓	
RTPØ 105, 190, 270 - Beta Liner		✓		✓	
RTPØ 350, 460 - Alpha, Beta Liner, Beta Canister			✓	✓	✓
Service Fixtures (Vacuum, Nitrogen, Compressed Air, Nozzle for BioVap)		✓	✓	✓	✓
Spray Ball (CIP) with Manual Ball Valve			✓		
Spray Gun (WIP) with Manual Ball Valve		✓	✓		
Sterile Continuous Liner		✓		✓	✓
Sterility Test Pump		✓			
Temperature and Relative Humidity Monitoring (only for process chamber)		✓	✓	✓	✓
Rear view monitor		✓	✓	✓	✓
UV Lamp				✓	✓
Weighing Scale Granite Slab		✓	✓		✓
Sharps (inside)		✓			

26

CBI-U	CBI - T	CBI-III	CBI-H	Description	PTC Model Code
✓			✓	No Passthrough Chamber	PTC0
✓	✓	✓	✓	(Small Static PTC, without gloves, with automated internal opening (vertical sliding	PTC1
		✓	✓	Small Static PTC, without gloves, with manual internal opening	PTC2
✓	✓	✓	✓	(Small Dynamic PTC, without gloves, with automated internal opening (vertical sliding	PTC3
		✓	✓	Big Static PTC, without gloves, with manual internal opening	PTC4
		✓	✓	Big Static PTC, with gloves, with manual internal opening	PTC5
✓				Big Dynamic PTC, without gloves, with manual internal opening	PTC6
✓	✓	✓	✓	Big Dynamic PTC, with gloves, with manual internal opening	PTC7

EQUIPMENT INTEGRATION

Isolation Technology offers the advantage of equipment integration without hampering the containment of the cabinet. This design allows a continuous and more efficient workflow process. Equipment can be integrated into the work zone, main chamber walls, or passthrough chamber walls, as needed and defined by the process and application.

Testing and validation is carried out to ensure isolator performance compliance to international standards, despite the integrations in the design.



LIST OF EQUIPMENT INTEGRATION OPTIONS

EQUIPMENT INTEGRATION/ CUSTOMIZATION EXAMPLES	CBI-U	CBI - T	CBI-III	CBI-H
Autoclave			✓	✓
Analytical Balance	✓	✓	✓	✓
Biosafety Cabinet			✓	
CCTV Camera	✓		✓	✓
CCTV Camera Provision	✓		✓	✓
Fume Cabinet Integration		✓		
Vacuum Oven / Tray Dryer integration		✓		
Non CO2 Incubator Integration	✓		✓	✓
CO2 Incubator Integration			✓	✓
Centrifuge Integration	✓	✓	✓	✓
Drybath Integration	✓			
Esco Sublimate freeze dryer	✓	✓	✓	✓
Refrigerated Microcentrifuge Integration	✓			
3rd party Freeze dryer	✓	✓	✓	✓



BioVap™ | Biodecontamination System

Esco BioVap™ is an effective hydrogen peroxide based biodecontamination system capable of achieving a 6-log reduction in bioburden. This system can be integrated into the HPI-G3 as our approach to a cost-effective biodecontamination.

Science Behind the Process

The Esco BioVap™ system employs a process of atomizing the hydrogen peroxide sterilant creating a dry fog after it is injected into the space. This unique system (patent pending) creates a charge on the atomized droplets as it pass through the nozzle.

Each droplet of the sterilant contains billions of reactive antimicrobials to effect a microbial kill. Through a mutual repulsion, the charged droplets repel each other and distribute through the space and are attracted to the negative charged surfaces. This causes the droplets to crash and burst on to the surfaces instead of gently settling.

This revolutionary biodecontamination system is not affected by temperature or relative humidity therefore there is no pre-conditioning requirement to the chamber before use leading to reduced cycle.

Specifications	
Air Injection Pressure	4 bar ±10%
Air Injection Flow rate	32 lpm ±10%
Injection Time	30 sec – 5 min
Dwell Time	30 min
Aeration Time	20 min
Total Decon Time	45 min – 1 hr
Sterilant Used in One Cycle	10 – 30 mL
Sterilant Injection Flow Rate	200 – 300 µL/sec
Sterilant	30% Hydrogen Peroxide

Levels of Biodecontamination

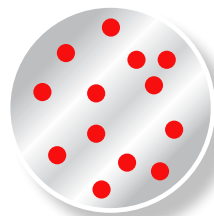

SANITIZATION
Two log-10⁻²

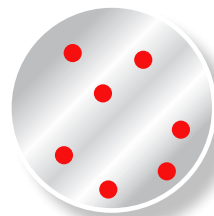

DISINFECTION
Five log-10⁻⁵

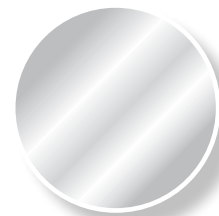

STERILIZATION
Six log-10⁻⁶

Control System

BioVap™ is controlled by PLC with operator interface via a touchscreen HMI terminal giving operator log on security and real-time display of cycle parameters.

Containment Barrier Isolator (CBI)

Testing and Validation

- Filter Leak Tests verify the integrity of the ULPA and HEPA filters as installed.
- Downflow Velocity Tests verify adequate unidirectional airflow velocities.
- Pressure Tested as Class 2 Containment Enclosure for process and pass chambers in accordance with ISO 10648-2
- Particle Counts (Air Cleanliness Tests) verify air cleanliness in accordance with ISO 14644-1.
- Product Ingress and Egress Tests determines if the isolator work zone can maintain ISO Class 5 during transfer procedures.
- Recovery Time Test determines the amount of time the main chamber takes to recover to ISO Class 4 in the event of a contamination event.
- Breach Test verifies user protection in case of a glove failure. Unit will become negative pressure with inward velocity of 0.7 m/s.
- Operator Comfort Tests include noise, light and vibration.



29

Pressure Test

Containment Barrier Isolator is a Class 2 Containment Enclosure in accordance with ISO 10648-2 standards.

Capable of carrying out a pressure test (Manual or Automated). Compressed air is injected to the chamber until it reaches 250 Pa. Measurements are taken every 10 mins for a total of 30 mins. These measurements are recorded and computed as per ISO 10648-2 standard.



SAFE GLOVE CHANGE PROCEDURE: REPLACING DISPOSABLE GLOVES

Safe change design system allows glove change at the middle of a process or when the equipment is in operation.



1. Pull the Glove/Sleeve outside the isolator



2. Fold the fingers of the glove inside the cuff ring



3. Remove the outer ring



4. Carefully roll the gloves from the middle groove to the outer groove



5. Take the new glove and ensure the thumb is at the top. Stretch the ring of the new glove over the port and over the old glove onto the middle groove



6. Install the ring up to the middle groove



7. Carefully loosen the old glove from the outer groove



8. Put the glove/sleeve inside the isolator



9. Working with one hand in the adjacent glove, carefully pull the old glove



10. The procedure is now complete

SAFE GLOVE CHANGE PROCEDURE: REPLACING THE SLEEVES



1. Remove the screws that secure the glove port cover



2. Remove the outer glove port cover



3. Remove the "O" ring



4. Carefully roll the ring of the glove from the inner groove to the outer groove of the port



5. Ensure that the old glove is inside the isolator



6. Take the new glove and ensure the thumb is at the top and stretch the "O" ring of the new glove over the port and over the old glove into the inner groove



7. Replace the "O" ring into the outer groove of the glove port



8. Working with one hand in the adjacent glove, carefully work from the outer ring and into the isolator. The old glove needs to be removed while under the new glove



9. Replace the glove port outer cover



10. Secure the port cover with the screws. The procedure is now complete

ESCO GLOBAL NETWORK

43 Locations In 23 Countries All Over The World

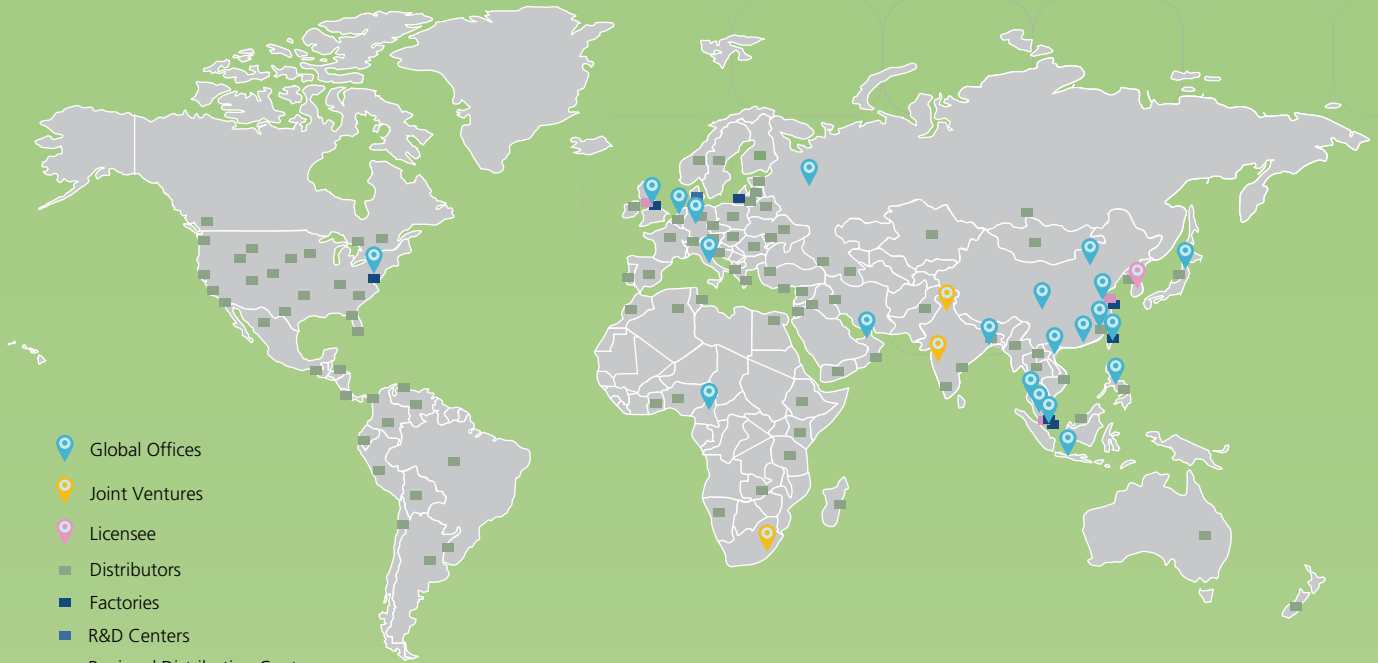

- Air Shower
- Aseptic Containment Isolator (ACTI)
- Ceiling Laminar Airflow Units
- Cleanroom Transfer Hatch
- Containment Barrier Isolator (CBI)
- Downflow Booth (DFB)
- Dynamic Floor Label Hatch
- Dynamic Pass Box
- Evidence Drying Cabinet
- Garment Storage Cabinet
- General Processing Platform Isolator (GPPI)
- Laminar Flow Horizontal Trolley
- Laminar Flow Straddle Units, Single and Double
- Laminar Flow Vertical Trolley
- Pass Box
- Soft Wall Cleanroom
- Sputum Booth
- Ventilated Balance Enclosure (VBE)
- Weighing and Dispensing Containment Isolator (WDCI)

Since 1978, Esco has emerged as a leader in the development of controlled environment, laboratory and pharmaceutical equipment solutions. Products sold in more than 100 countries include biological safety cabinets, fume hoods, ductless fume hoods, laminar flow clean benches, animal containment workstations, cytotoxic cabinets, hospital pharmacy isolators, and PCR cabinets and instrumentation. With the most extensive product line in the industry, Esco has passed more tests, in more languages, for more certifications, throughout more countries than any biosafety cabinet manufacturer in the world. Esco remains dedicated to delivering innovative solutions for the clinical, life science, research and industrial laboratory community. www.escoglobal.com.



Esco Pharma Pte Ltd
 21 Changi South Street 1 Singapore 486777 • Tel: +65 65420833
 Fax: +65 65426920 • Email: csis.pharma@escoglobal.com

Esco Technologies, Inc.
 2512 Metropolitan Drive, Suite 120 B
 Feasterville- Trevose, PA 19053-6738
 Tel: 215 322 2155 • Email: eti.pharma@escoglobal.com

Esco Gb Ltd
 Unit 2 R-evolution @ Gateway 36, Kestrel Way, Barnsley, S70 5SZ
 Tel: +44 (0) 1226 360 799 • Email: egb.pharma@escoglobal.com

Esco Global Offices: Bangladesh | Cameroon | China | Denmark | Germany | Hong Kong | India | Indonesia | Italy | Japan | Lithuania | Malaysia | Myanmar | Philippines | Russia | Singapore | South Africa | South Korea | Taiwan | Thailand | UAE | UK | USA | Vietnam



Containment Barrier Isolator, Brochure, A4, v4, 12112019
 Esco can accept no responsibility for possible errors in catalogues, brochures and other printed materials. Esco reserves the right to alter its products and specifications without notice. All trademarks and logos in this material are the property of Esco and the respective companies.